



RACK AND PINION DRIVE

INSTALLATION MANUAL CAYMAN 202

14.02.2025

FORD TRANSIT from 2015

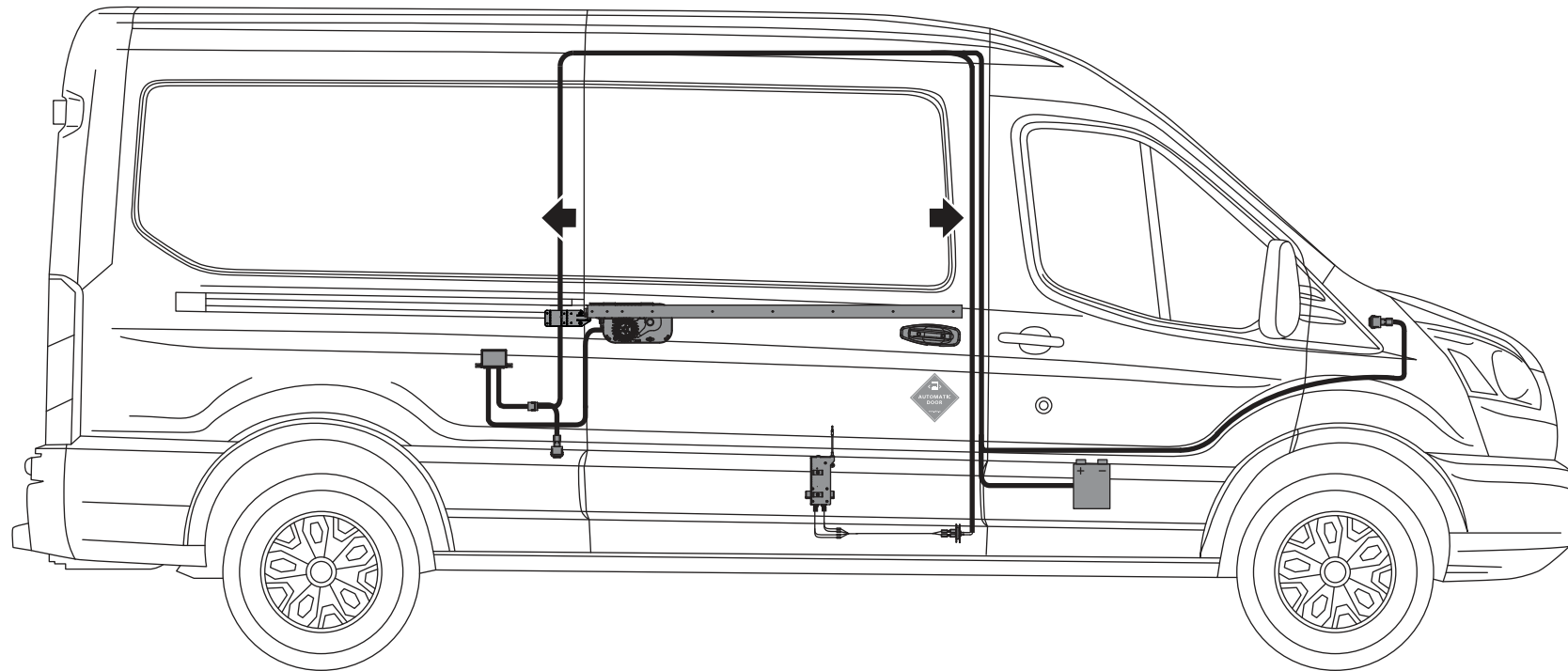

Symbols and means of visualisation

Warnings



Warning notices are used in these instructions to warn you of damage to property and personal injury.

- ▶ Always read and follow these warnings.
- ▶ Follow all measures labelled with the warning symbol and warning word.

Warning symbol	Warning word	Meaning
	WARNING	Hazards for persons. Non-observance can lead to serious injuries.

Other symbols and visualisation aids

Important information and technical instructions are specially emphasised to clarify correct operation.

Symbol	Meaning
	means 'Important information'. Information to prevent material damage, to understand or optimise work processes.
	means 'additional information'

- ▶ Symbol for an action: You have to do something here.
- ▶ Keep to the sequence for several action steps.

Product liability

In accordance with the manufacturer's liability for its products as defined in the Product Liability Act, the information contained in this brochure (product information and intended use, misuse, product performance, product maintenance, information and instruction obligations) must be observed. Failure to do so releases the manufacturer from his liability obligation.

Applicable documents

Type	Name
Operations Manual	Cayman 202

The plans are subject to change. Only use the latest version.

Symbols and means of representation.....	2
Product liability.....	2
Applicable documents.....	2
1 Safety instructions.....	3
1.1 Intended use.....	3
1.2 Safety instructions.....	3
1.3 Safety-conscious working.....	3
1.4 Testing the installed drive.....	3
1.5 Environmentally conscious working.....	3
2 List of tools and aids.....	4
3 Scope of delivery and completeness.....	4
4 Transport and storage.....	4
5 Product description.....	5
5.1 Product description.....	5
5.2 Technical data.....	5
5.3 Operating elements.....	6
5.4 Drive functions.....	6
6 Installation.....	7
6.1 Instructions before starting installation.....	7
6.2 Wiring harness and connection diagram.....	8
6.3 Main wiring harness layout.....	9
6.4 Controller installation and minus terminal connection.....	10
6.5 Positive wire connection to power supply.....	11
6.6 Actuator and actuator wiring harness installation.....	12
6.7 Layout of sliding door limit switch and control button installation.....	14
6.8 Rack mounting.....	15
6.9 Brackets mounting.....	17
6.10 Preliminary preparation.....	18
7 The first cycle.....	19
7.1 The first cycle of rack-and-pinion drive.....	19
7.2 Drive adjustment.....	20
7.3 Mounting of door drive cover and decorative cover strip.....	21
7.4 Functions of the rack-and-pinion drive and setting the controller.....	22
7.5 Warning sticker.....	23
8 Optional accessories.....	24
8.1 Remote control.....	24
8.2 Touch button.....	24
8.3 Handle covers.....	25
8.4 Safety edge on door edge.....	26
9 Notes.....	28
9.1 Emergency door opening from the outside.....	28
9.2 Emergency door opening from the inside.....	28
10 Manual mode reset.....	29
10.1 Rack-and-pinion drive.....	29
11 Extensions.....	30
11.1 Switching the remote control receiver on/off with the vehicle's central locking system.....	30
11.2 Coupling the electric step with the Ador drive.....	31
11.3 Connection diagram of the extensions.....	31
12 Information.....	32

1.1 Intended use

The Cayman 202 rack-and-pinion drive is designed for the automatic opening and closing of sliding doors. The door operator is only suitable for use in panel vans.

This door operator fulfils the requirements of UN/ECE R107, 7.6.5.

Any use other than the intended use, e.g. permanent manual operation, and all modifications to the product are not permitted.

Observe the 'ADOR product information for drives'.

1.2 Safety instructions

- > Prescribed installation and maintenance work must be carried out by qualified personnel.
- > Assembly requires holes to be drilled in the body parts. The exact position of these drill holes is required in order to maintain the positional accuracy of the assembled components.
- > The country-specific laws and regulations must be observed for safety inspections must be observed.
- > Unauthorised modifications to the drive exclude any liability on the part of ADOR for resulting damage.
- > ADOR accepts no warranty for combinations with third-party products.
- > Only original ADOR parts may be used for repair and maintenance work.
- > In accordance with the Machinery Directive 2006/42/EC, a hazard analysis must be carried out before the door system is a risk analysis must be carried out and the door system labelled in accordance with the CE marking directive 93/68/EEC.
- > Observe the latest directives, standards and country-specific regulations, in particular:
 - > DIN VDE 0100-600: 'Installation of low-voltage systems; Part 6: Tests'
 - > DIN EN 60335-2-103, DIN 18263-4
 - > Accident prevention regulations, in particular BGV A1 'Principles and prevention' and BGV A3 DA 'Implementation instructions for the accident prevention regulation 'Electrical Installations and Equipment'



The product should be installed in such a way that easy access to the product for repairs possible repairs and/or maintenance with relatively little effort and that any and any removal costs are not disproportionate to the economic value of the product. disproportionate to the value of the product.

1.3 Safety-conscious working

- > Secure the workplace against unauthorised access.
- > Only use the cables specified in the cable plan.
- > Secure loose, drive-internal cables with cable ties.
- > Before working on the electrical system: Disconnect the power supply to the starter battery.
- > Always use insulated wire end ferrules for stranded wires.
- > Ensure sufficient lighting.
- > Risk of injury when the sliding door is open. Hair, clothing, cables, etc. can be pulled in by moving parts!
- > Risk of injury due to unsecured crushing, impact, shearing and pull-in points!
- > Risk of injury due to sharp edges on the bodywork!
- > Risk of injury due to freely moving parts during assembly!

1.4 Testing the installed drive

Measures to safeguard against and avoid crushing, impact, shearing and drawing-in points:

- > Check the function of the automatic reversing in the event of contact with an obstacle.
- > Carry out a safety analysis (hazard analysis).



1.5 Environmentally conscious working

- > When disposing of the door system, separate the different materials and recycle them.
- > Do not dispose of batteries and rechargeable batteries with household waste.
- > Observe the legal regulations when disposing of the drive and batteries/rechargeable batteries.

2 List of tools and aids

Rivet nut _____	15 pieces
Drills 2,5; 3,2; 5; 6,5 _____	1 piece each
Drill _____	1 piece
Cutter _____	1 piece
Wire for pulling through _____	3 metres
Hacksaw _____	1 piece
Blade screwdriver _____	1 piece
Hammer _____	1 piece
Clip remover _____	1 piece
Center punch _____	1 piece
Combination pliers _____	1 piece
Cross-slotted screwdriver _____	1 piece
Torch _____	1 piece
Spanner wrenches, Open-end wrenches _____	1 set
Knife _____	1 piece
Sliding calipers _____	1 piece
Riveter for blind rivet nuts Gesipa GBM10 _____	1 piece
Set of interchangeable heads 10 up to 17 mm _____	1 piece
Ratchet _____	1 piece
Industrial spirit _____	1 bottle
Set of Allen keys _____	1 set
Set of Torx bits _____	1 set
Cutting nippers _____	1 piece
Metal ruler _____	1 piece
Taper drill 4 up to 24 mm or peeler drill _____	1 piece each
Electrical socket extender _____	1 piece

There may appear some edge fin after making holes, finally it leads to the damage of the paint coat. There are symbolic notations on the places where some treatment is required:

-  --- Remove edge fin
-  --- Unedge
-  --- Treat with acid-free antirust liquid

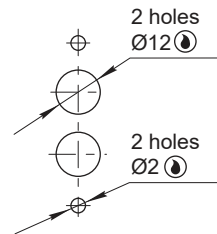

3 Scope of delivery and completeness

- ▶ Open the packaging units and check for completeness.

Cayman 202 rack-and-pinion drive for sliding doors

- > Drive
- > Controller
- > Main wiring harness
- > Rack according
 - > Spacer strip (3x)
 - > Slab
- > Mounting set
- > Cradle
- > Actuator
- > Contacts

Accessories (option)

- > Remote control (1 or 2 keys)
- > Touch button
- > Outside door handle cover
- > Safety edge on door edge
- > Operation of sliding door drive via inside and outside handle

4 Transport and storage.

- > The rack-and-pinion drive is not designed for hard knocks or for falling from a height. Do not throw or drop.
- > Storage temperatures below -30 °C and above +60 °C can damage the device.
- > Protect from moisture.

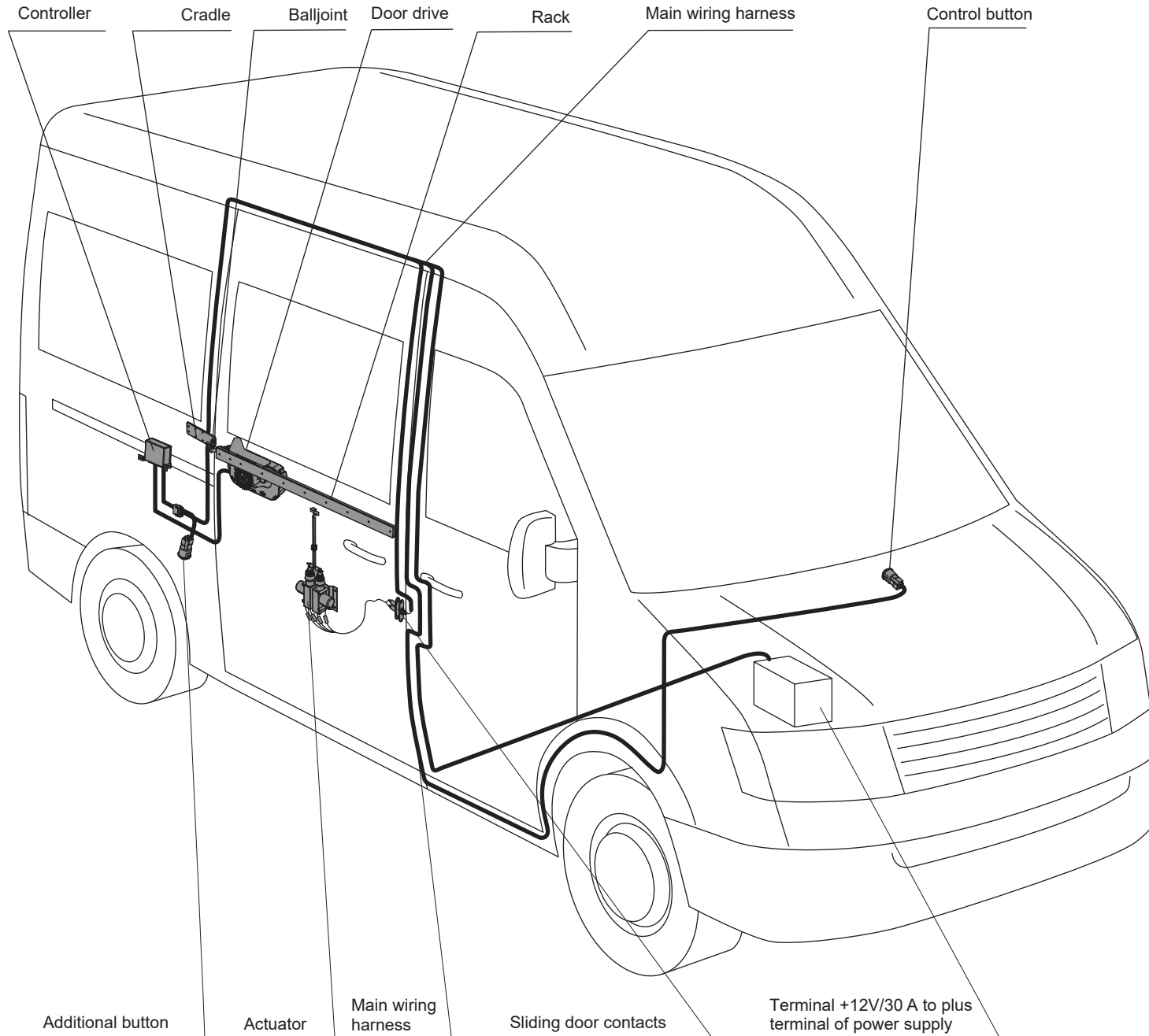

5.1 Product description

This rack-and-pinion drive is designed to open and close sliding door in Ford Taunus from 2015.

The layout of the units is shown on the base of the universal minibus prototype.

i This manual describes the installation of the rack-and-pinion drive with the widest range of drive units. If you install the rack-and-pinion drive without latch actuator or remote control then you have to omit the corresponding items of the manual.

5.2 Technical data

CAYMAN drive is designed for opening and closing doors in minibuses working as taxi buses or camper vans. You will find a list of models on the cover page. If your model is not listed, please ask us.

Power consumption (rating)	70 W
Power consumption (max)	250 W
Door-opening time, (it depends upon the opening width adjustment)	2 - 6 sec.
Door-closing time, (it depends upon the opening width adjustment)	2 - 6 sec.
Category temperature range	-40°C up to +40°C
Maximum slop for the door to be closed	15%
Resources	Not less then 1.200. 000 cycles
Maximum drive power	370 N (37 kg)



Durability and failure-free operation of Ador's drive depend directly on the quality of installation. Installation in specialised workshops is recommended. Experienced non-specialists should prepare themselves well and seek help if necessary.

5.3 Operating elements

Ador's drive is an electromechanical device powered from electric battery of a minibus. The drive consists of 2 parts:

a latch actuator and a sliding door drive

The latch actuator opens its latch, the sliding door drive opens and closes its door.

The drive control is performed with the help of:

- **Control buttons**
These buttons are designed for controlling the door and system adjustment.
- **Remote control**
It is used for controlling the door.

5.4 Drive functions

- **Opening and closing**
- **Stopping**
- **Automatic rollback**
- **Beep during opening/closing**
- **Adjustment of opening width**

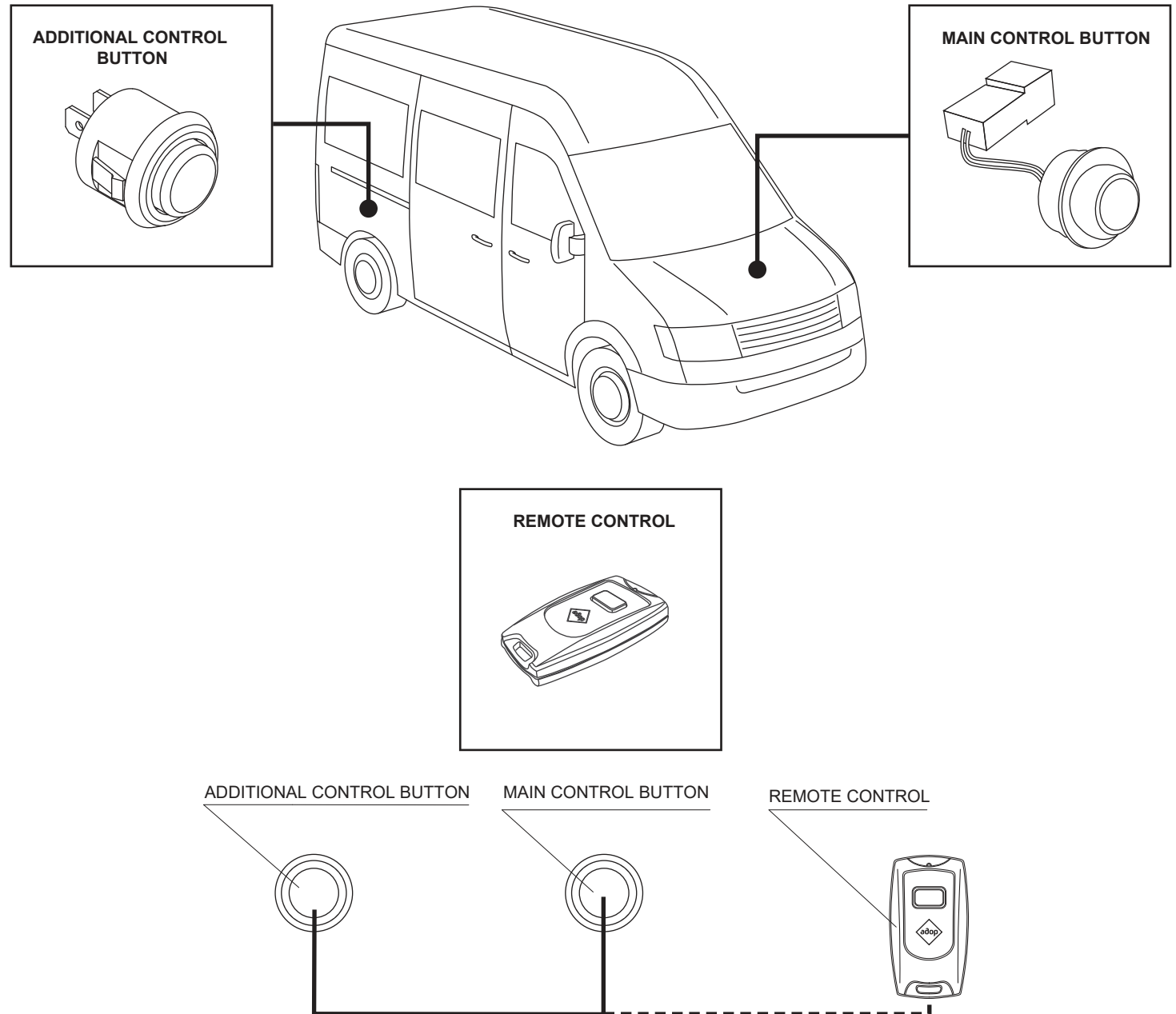

6 Installation

6.1 Instructions before starting installation

Before installing the drive, the position of the sliding door must be checked. This setting affects the operation of the drive.

1. Wash out the guides of the door slide with petrol and wipe them with a dry cloth.
2. Wash out the door locking mechanism, dry and lubricate with e.g. WD-40.
3. Remove the door pivot.
4. Adjust the position of the door in relation to the door opening with parallel gaps. The closed door must not sag or protrude inwards beyond the van.
5. Adjust the latch pin and the latch holder on the C-pillar to ensure the lowest possible closing speed.
6. Check the seal when the door is closed. The seal must not be crushed. Otherwise, remove the seal and bend open its edge at the compressed points.
7. Fit the door pins and adjust their position.
8. Open and close the door.
9. Check the settings of the top, centre and bottom holders. The door must move easily and without jerking in the door guide; it must open and close freely. The correctly adjusted door must fit tightly against the seal in the closed position and have even, uniform gap dimensions.

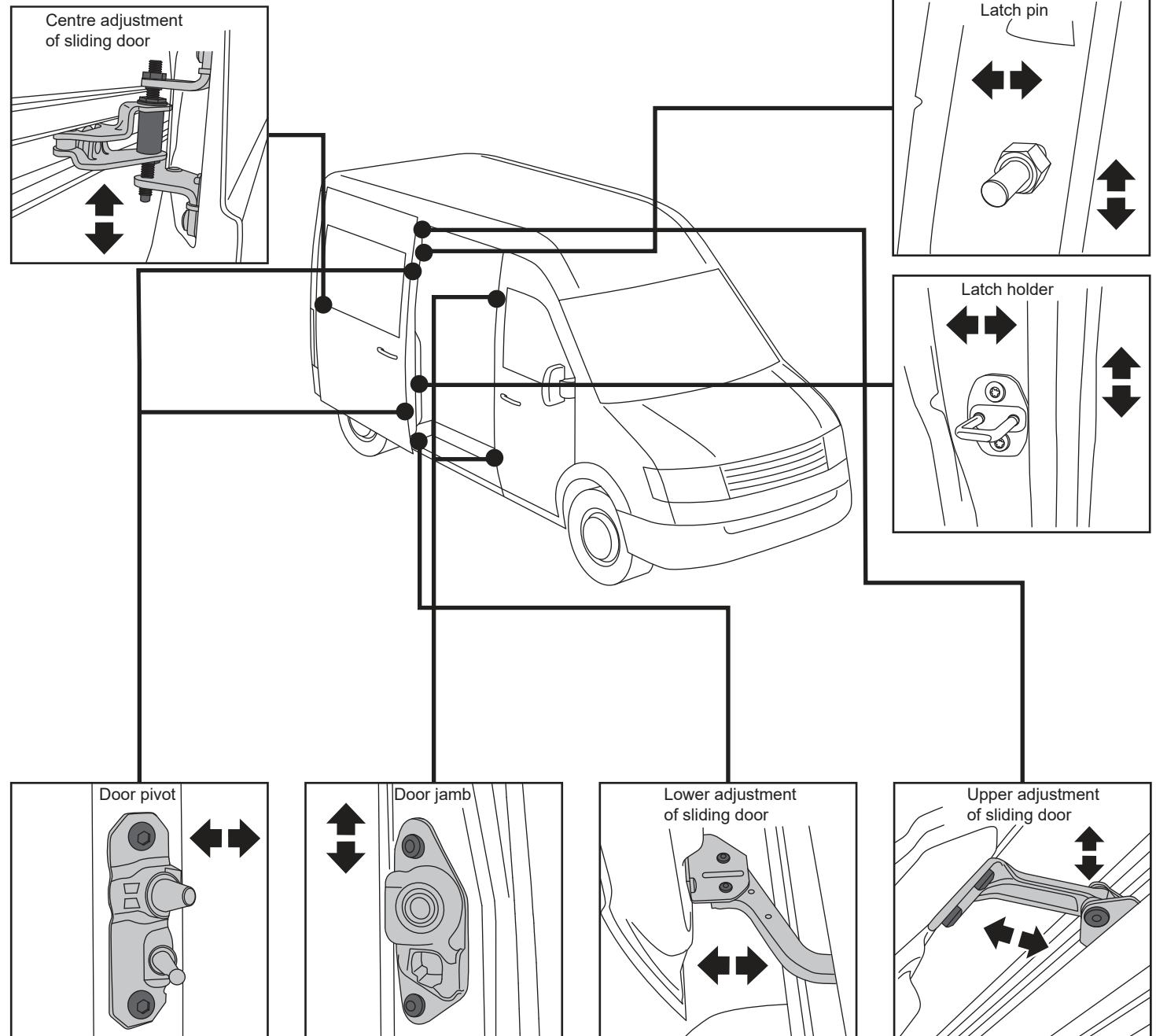

6.2 Wiring harness and connection diagram

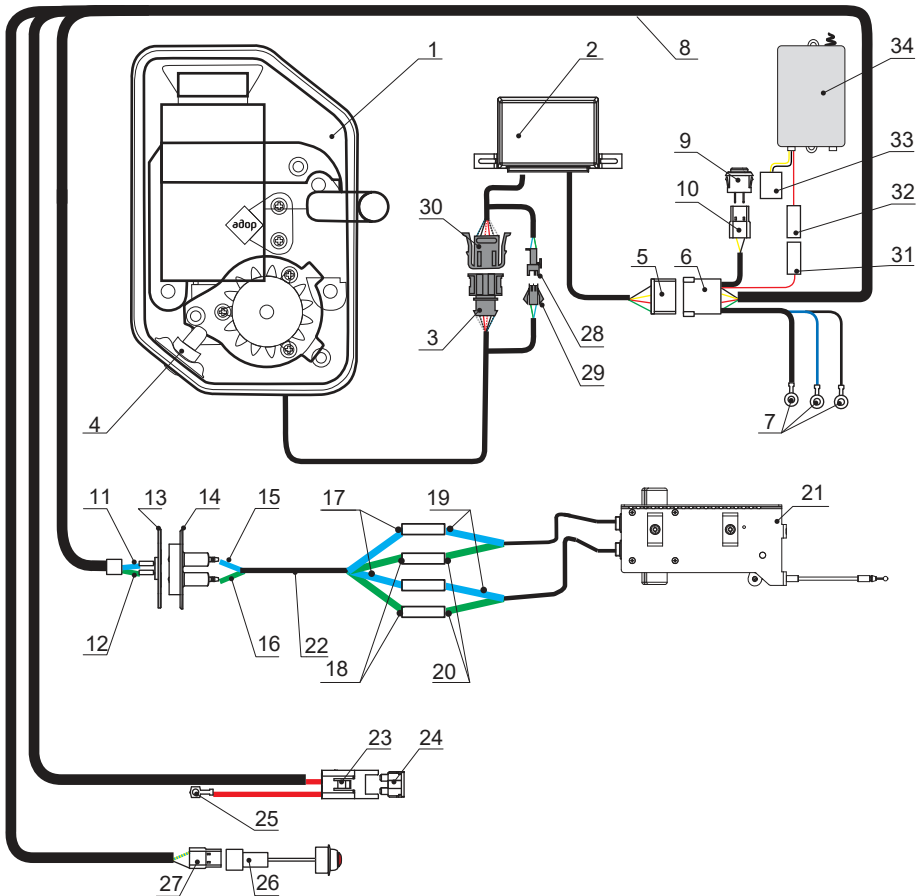

1. Cayman 202 drive
2. Cayman 202 controller
3. Drive wiring harness coupling
4. LED Torch
5. Controller wiring harness plug
6. Main wiring harness coupling
7. Terminals of the ground wires "-" to the minibus's body
8. Main wiring harness
9. Additional button
10. Additional button connector and remote control
11. Terminal of main wiring harness's blue wire to the fixed contacts group
12. Terminal of main wiring harness's green wire to the fixed contacts group
13. Fixed contacts group
14. Movable contacts group
15. Terminal of the activator blue wire to the movable contacts group
16. Terminal of the activator green wire to the movable contacts group
17. Terminal of the activator blue wire
18. Terminal of the activator green wire
19. Terminal of the activator blue wire
20. Terminal of the activator green wire
21. Actuator
22. Actuator wiring harness
23. Terminal of 30 A fuse red wire
24. 30 A fuse
25. Plus red wire terminal (+12V) to plus terminal of power supply
26. Main control button
27. Main control button connector
28. LED torch coupling
29. LED torch plug
30. Controller wiring harness plug
31. Main harness +12V coupling
32. Main harness +12V plug
33. Reciever coupling remote control or/and drive control module to 10.
34. Reciever remote control or/and drive control module

6.3 Main wiring harness layout 030.00.007.0005

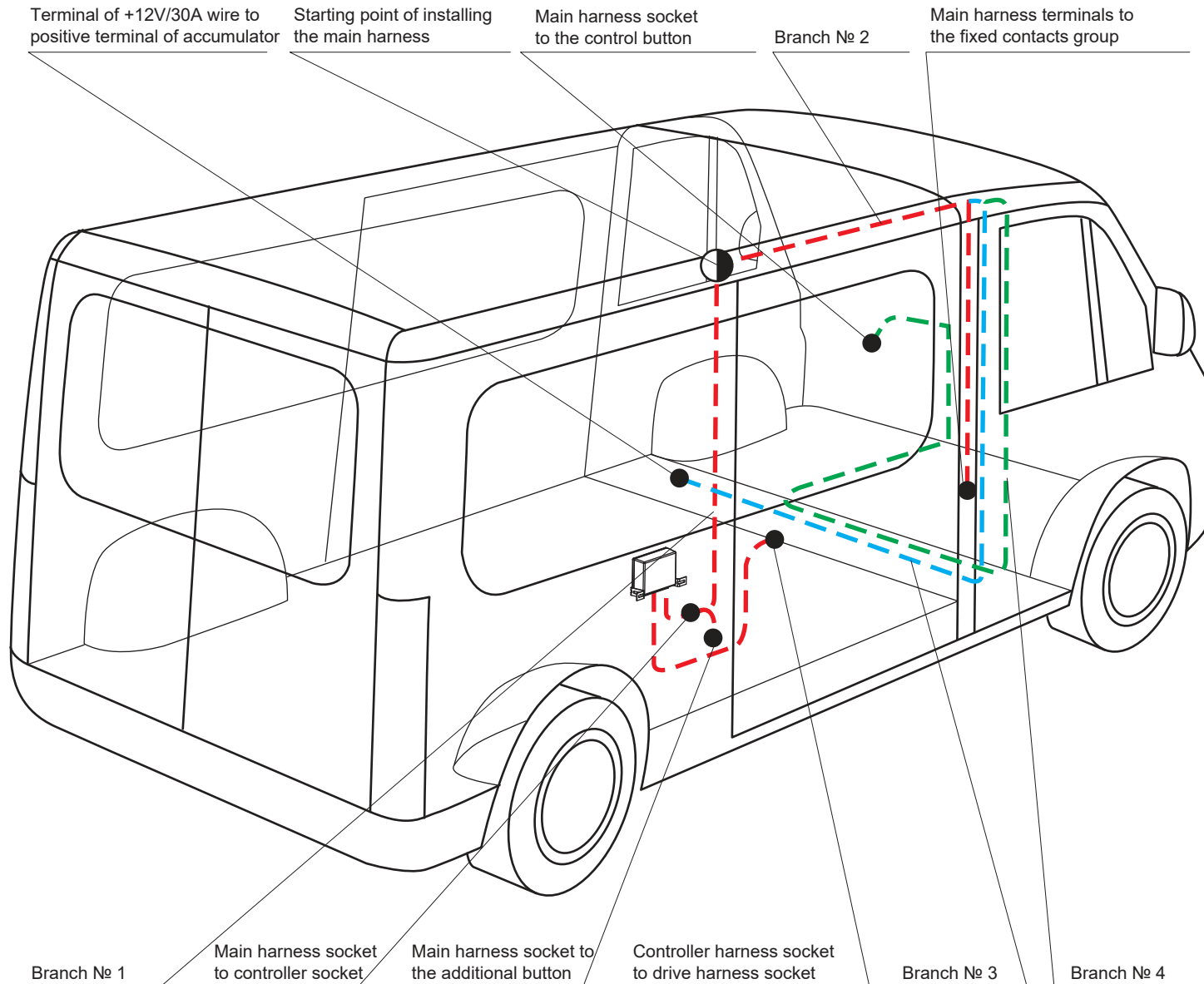

All wires must be protected and firmly attached to avoid any breakage, abrasion or chafing.

When installing the main harness use steel wire to conceal the harness in the hidden places. Disposition of the main harness is shown in the picture. Be careful while installing the harness insulating material must not be damaged.

Begin installing the main harness at the starting point as shown in the picture in the following order:

- Extend branch №1
- Extend branch №2
- Extend branch №3
- Extend branch №4

When extending branch №1 disconnect socket from the main harness. Do not forget to mark the colours of the wires in the socket.

6.4 Controller installation and minus terminal connection

In the car C-pillar place and screw up a controller with two self-tapping screws 4,2x12 from the hardware bag as shown in fig. 1

To fix ground wire «-» terminals it is required to make a hole with diameter \varnothing 6.5 mm in any place of the car inside bar, next to the controller as shown in fig. 1.

Remove the paint around the hole completely so you can see metal in order to provide a good contact as shown in fig. 2.

With the bolt M6x14, toothed washer and the nut M6 from hardware bag fix the ground wire «-» terminals as shown in fig. 3.

The toothed washer must be between terminals and a car body.

After tightening an M6 screw, apply the rust proofing on the surface with damaged rust-proofing paint.

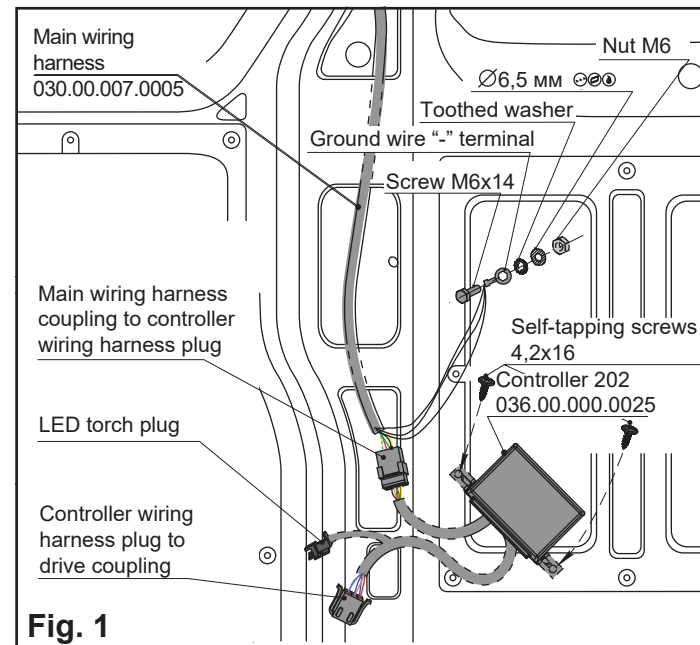

Fig. 1



It is necessary to place the controller so as working hole looked down to prevent the controller card from ingress and accumulation of condensate (v. fig. 1)

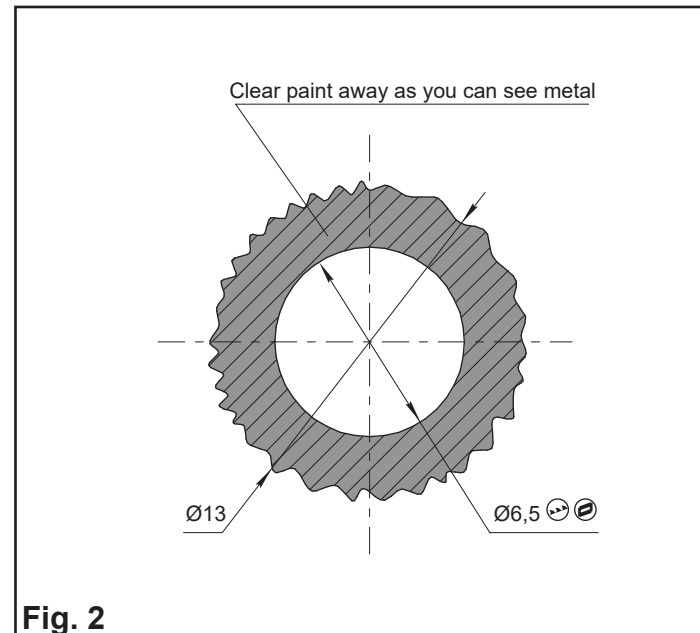

Fig. 2

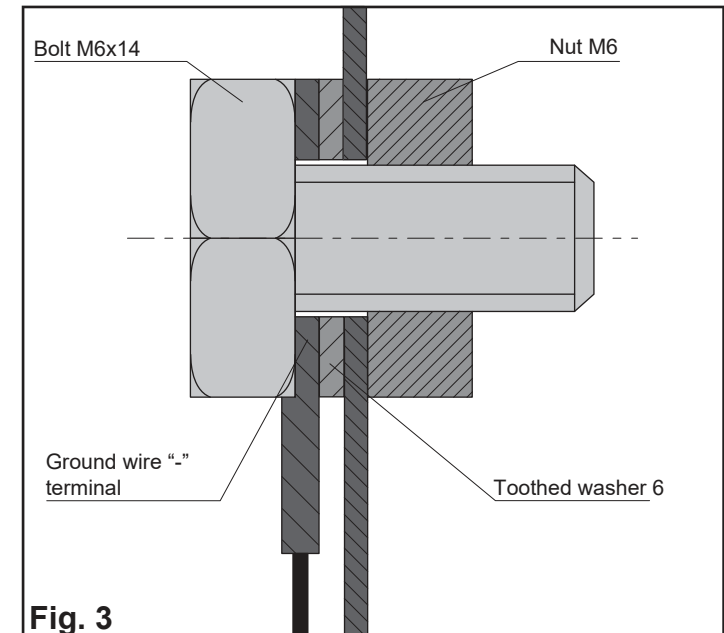

Fig. 3

6.5 Anschluss der Klemme an den Pluspol der Starterbatterie



Abb. 5

Die Klemme des roten Kabels (+12V) des Kabelbaums an eine nicht belegte Schraube des Pluspols der Starterbatterie, die sich im Fussraum des Fahrersitzes befindet, anschliessen und mit der Mutter befestigen.

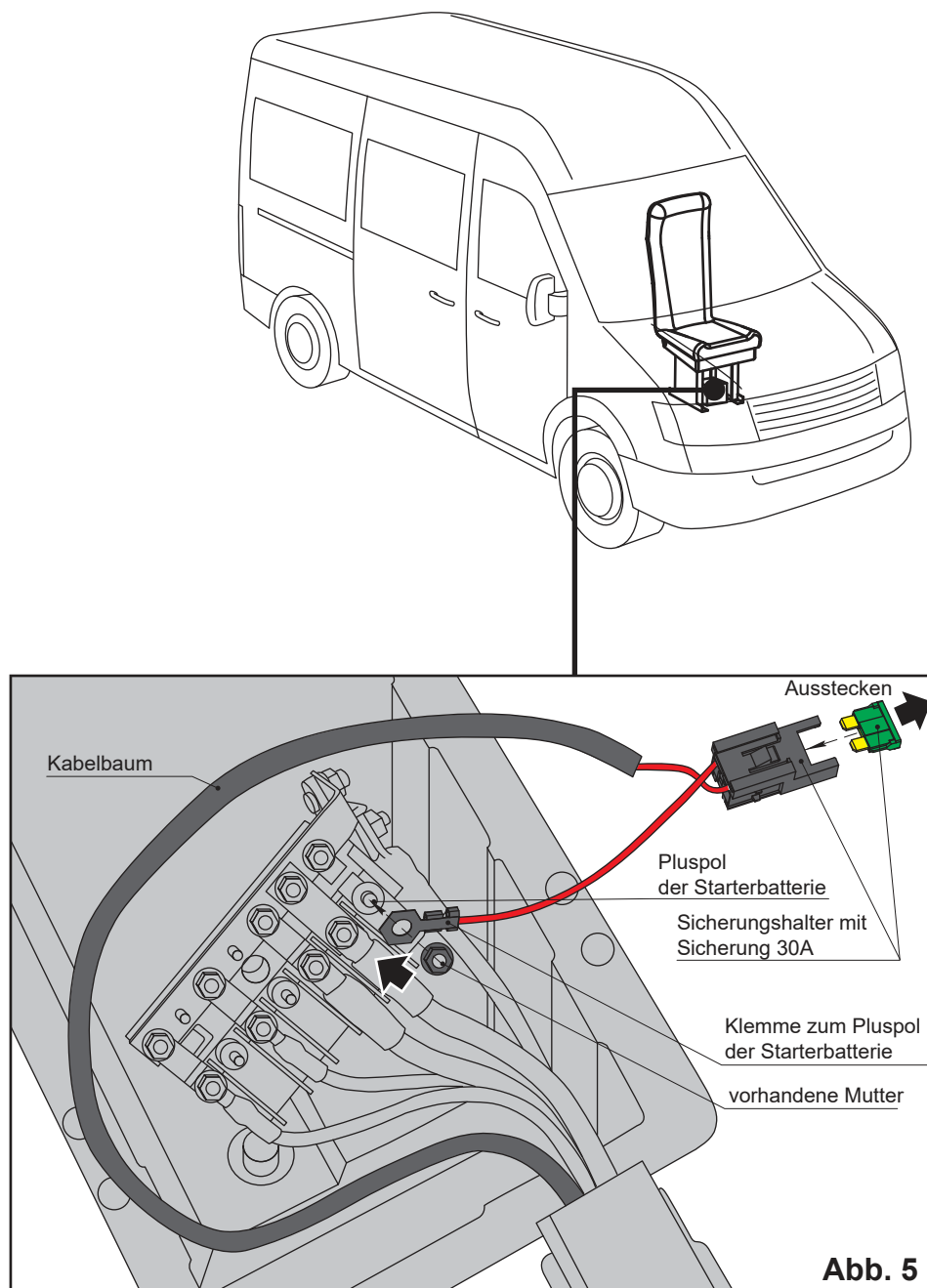

Vor diesem Anschluss die Sicherung 30A aus den Sicherungshalter ausstecken!
Die Sicherung erst nach vollständiger Installation der elektrischen Verbindungen einstecken.

6.6 Actuator 030.31.000.0003 and actuator harness installation 030.10.007.0001

i The movable contacts group can also be in the contact switch area of the of the vehicle.

Direct connection of actuator (blue- blue)

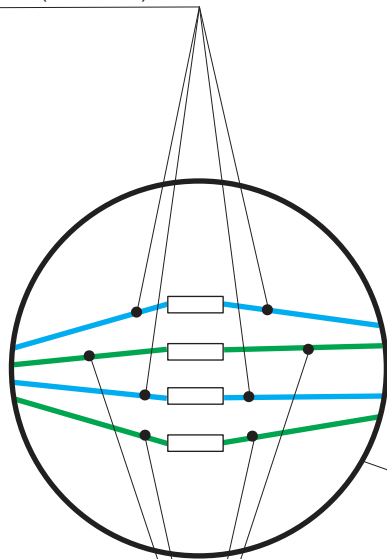

Direct connection of actuator (green - green)

Inside handle
Actuator harness
030.10.007.0001

Blue wire of the
actuator harness

Green wire of the
actuator harness

Movable contacts group
030.00.006.0001

Actuator
030.31.000.0003

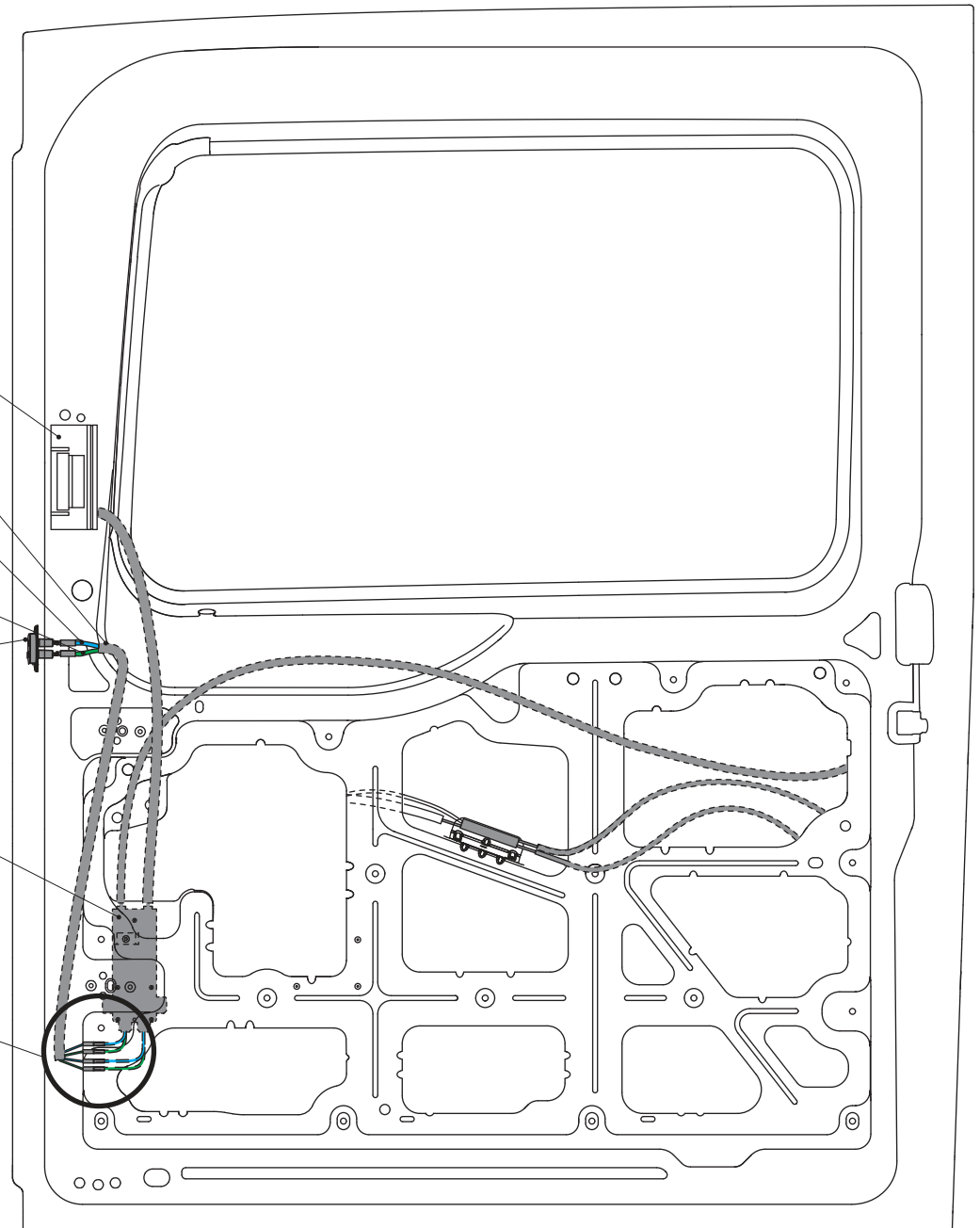
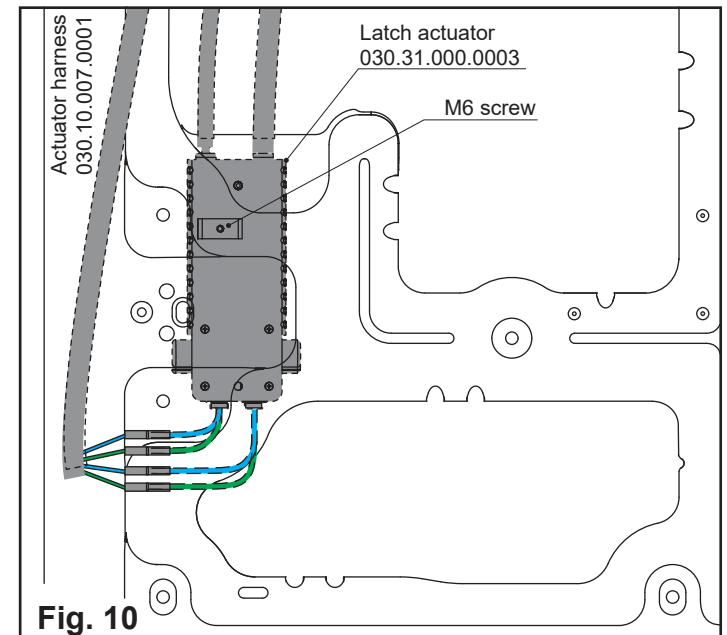
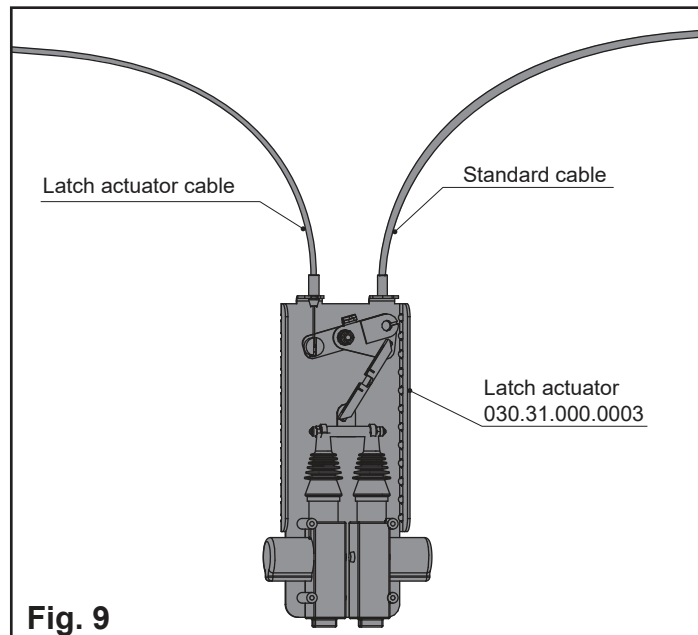
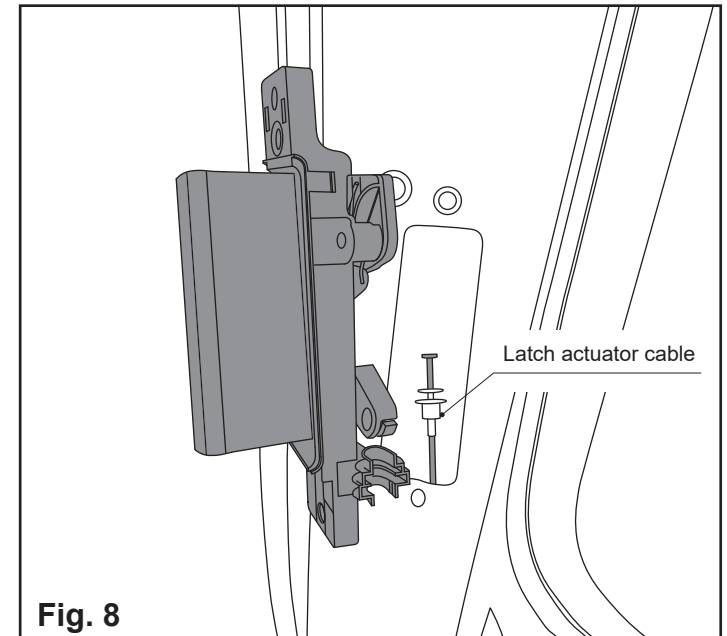
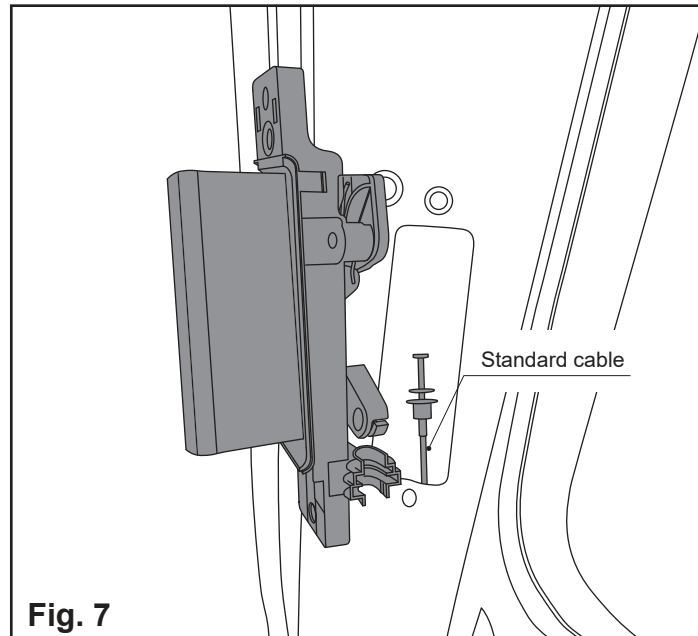

Fig. 6

Installation of the actuator 030.31.000.0003

1. Dismantle the inside handle and remove the existing existing bowden cable (Fig. 7).
2. Clamp the bowden cable latch actuator to the inside handle and refit the inside handle (Fig. 8).
3. Connect the standard cable to the latch actuator (Fig. 9).
4. Drill a $\text{\O}6.5$ mm hole at the point suitable for mounting the latch actuator.
Insert the latch actuator into the door recess and secure it with an M6 screw (Fig. 10).
5. Connect all cable connections, see page 12.

i When routing the bowden cables, ensure for freedom from torsion and direct connection



6.7 Layout of sliding door limit switch 030.00.006.0001 and control button installation

Movable contacts group

Mark the drill holes as shown in Fig. 10.
Drill two holes with $\varnothing 14$ mm and two holes with $\varnothing 2.5$ mm.

Attach the blue cable to the upper flag and the green cable to the lower one, see page 12.

Secure the movable contacts group with two countersunk screws ST3.5x19 (supplied), Fig. 10.

Fixed contacts group

The position of the fixed contacts group can be adjusted by opening and closing with contact marks on the paint, Fig. 11.

Alternatively, the position between the sliding door and the body can be measured.

Mark the drill holes as shown in Fig. 10.
Drill one hole with $\varnothing 20$ mm and two holes with $\varnothing 2.5$ mm.

Secure the fixed contacts group with two countersunk screws ST3.5x16 (supplied), Fig. 10.

Attach the blue cable to the upper lug and the green cable to the lower one.

i The contacts group can also be in the area of the contact switches of the vehicle.

The control button can be positioned anywhere. One possibility is in the dashboard of the vehicle. To do this, drill a hole of $\varnothing 23$ mm at the desired location. Press the control button into the hole the hole, before attaching the coupling for the control button is attached (Fig. 12).

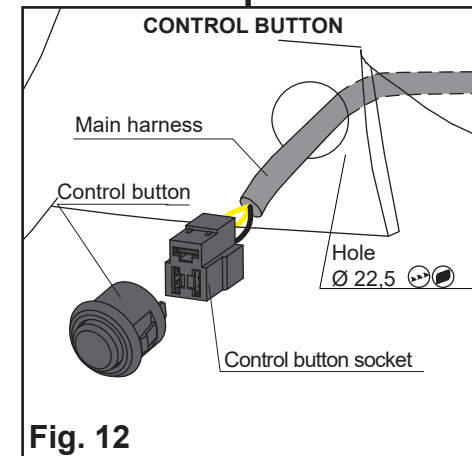
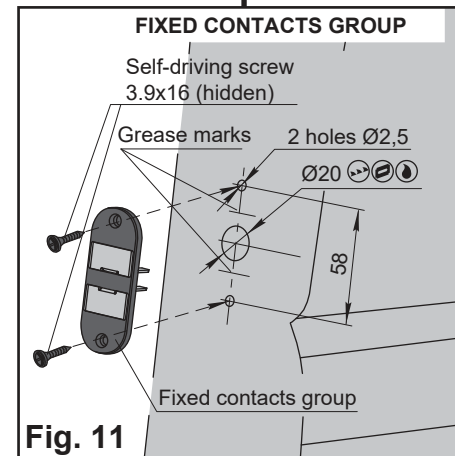
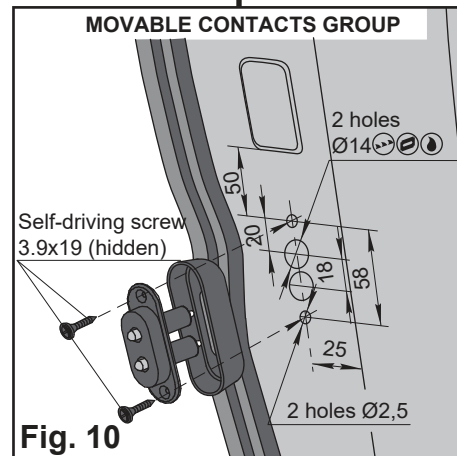
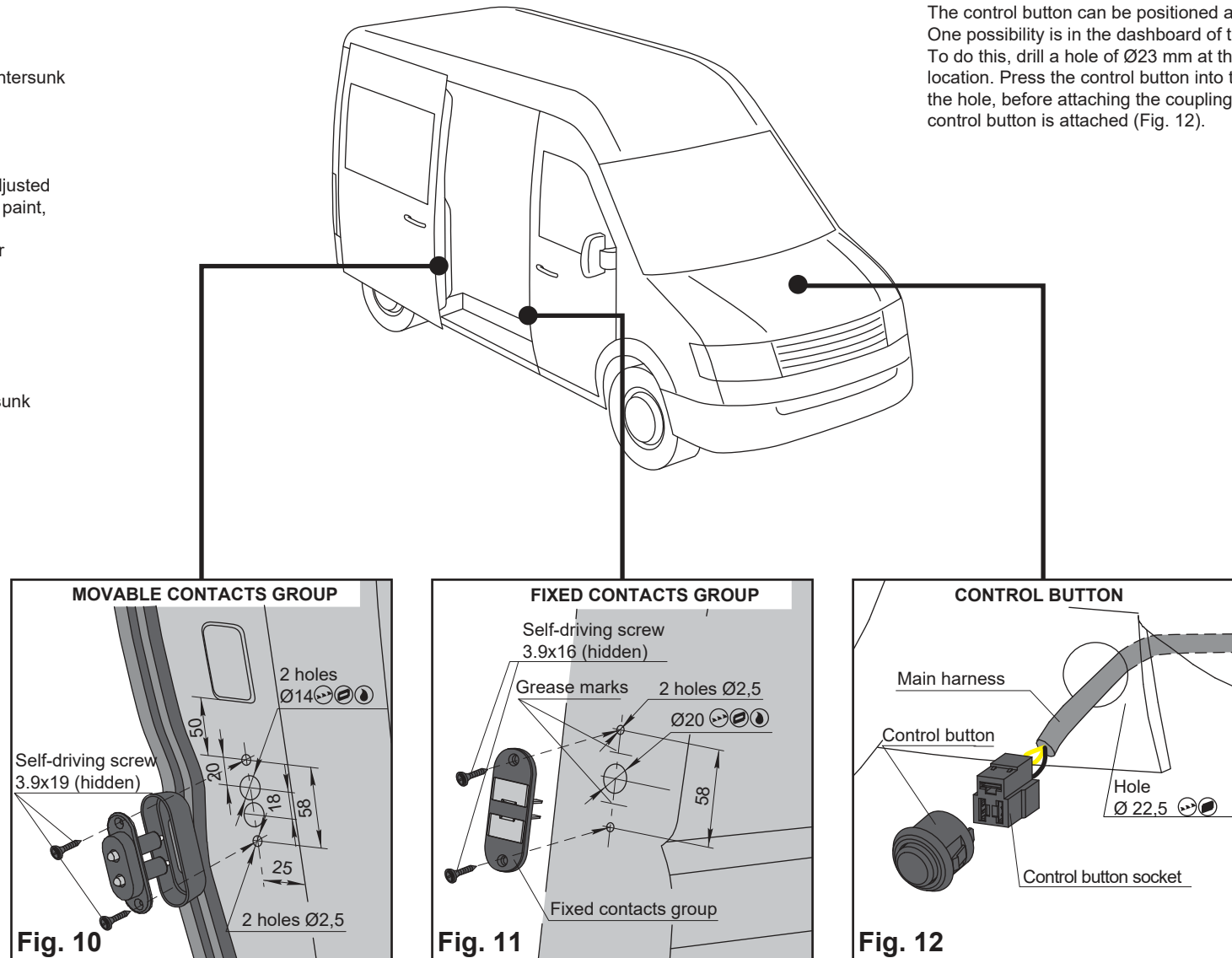

6.8 Rack mounting

The length of the rack depends on the installation variant.

! Only saw off the rack on the left!

Fasten the rack with 1x to 3x spacer H4 depending on the installation situation.

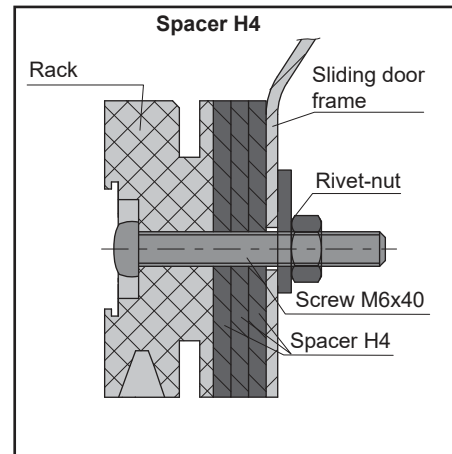
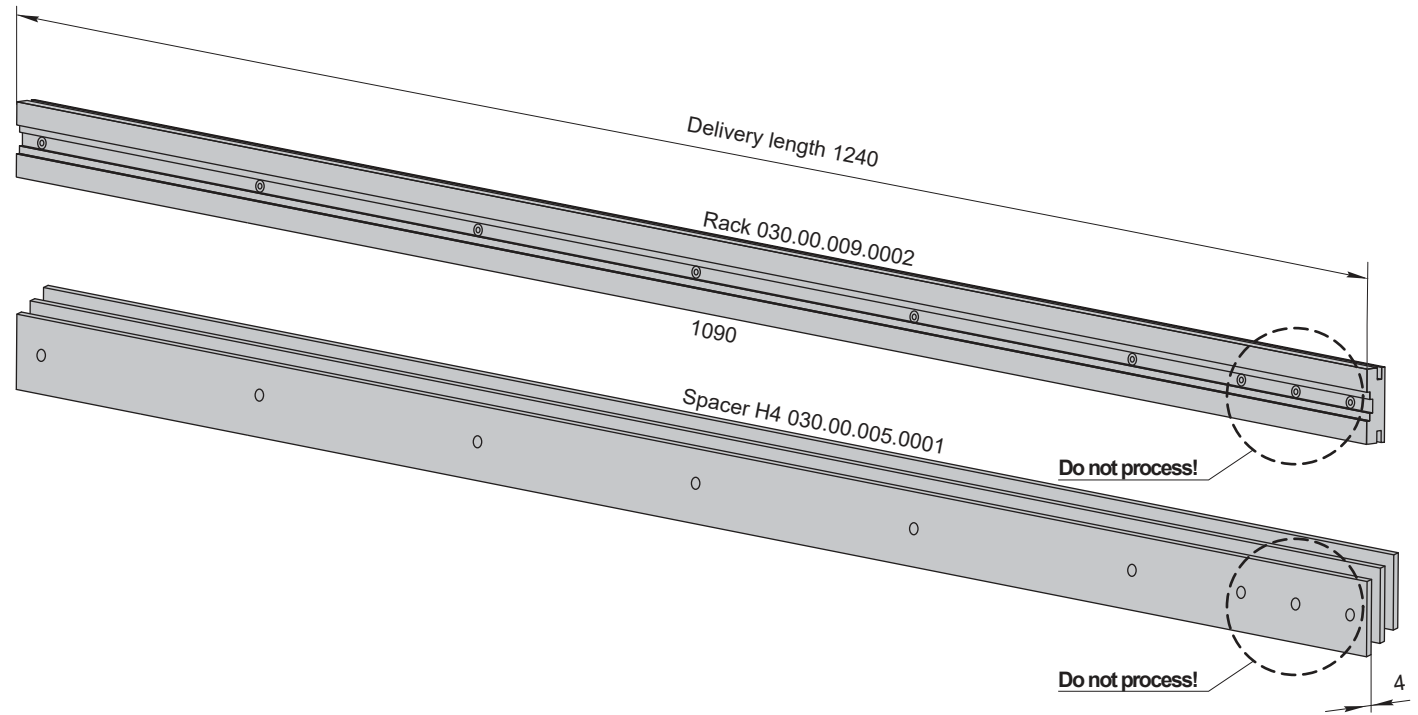

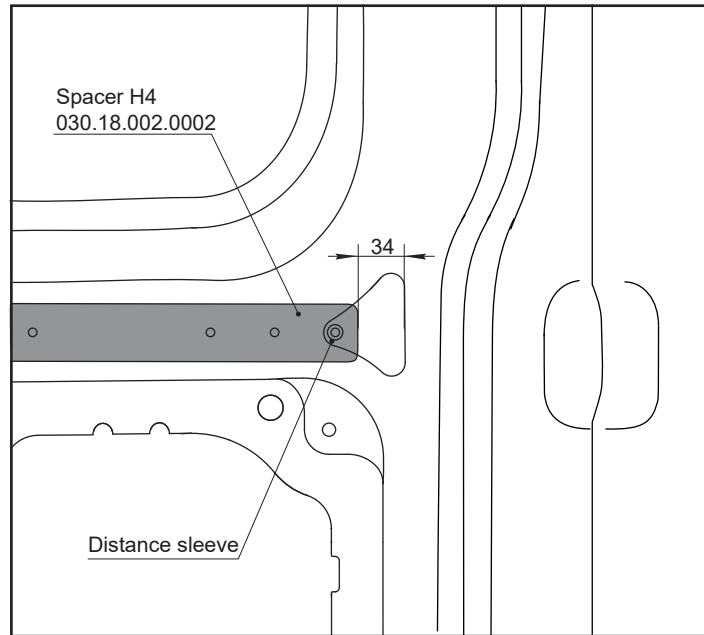
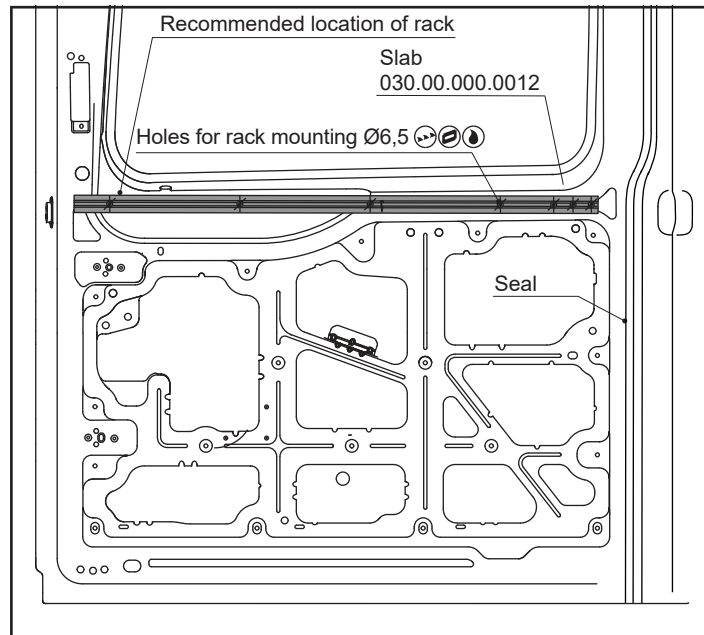

Fig. 14



This page shows the recommended installation location for the rack on the sliding door.

Remove the door panelling when the sliding door is unhinged or closed sliding door.

The recommended position for the rack is shown in Fig. 14.

Use the drill holes in the rack to align the drill holes on the sliding door with a marker.



The four holes on the right and one on the left are required for fastening. The rack may be fastened in the centre through a hole.

Make a mark on these markings with a centre punch. Use a $\text{Ø}4$ mm drill to drill through the sheet metal at all markings. All holes must be aligned.

Drill the four holes on the right with a step drill to $\text{Ø}6$ mm.

Fasten the guide rail with the following with the following scope of delivery:

1. screws M6x40
2. M6 nut on mounting plate

6.9 Bracket mounting 030.31.000.0001

Remove the door seal in the mounting area of the bracket, Fig. 15.

Position the bracket on the C-pillar as follows:

Mark the drilling points over the drill holes in the bracket, Fig. 16.

! Make sure that a distance of **9 mm ± 1 mm** between the level B of the bracket and level A of the rack, Fig. 17

Drill 2 holes Ø6.5 mm and 5 holes Ø5 mm according to the markings, Fig. 16.

Fasten the bracket first with 2 screws M6x25, then with rivets 4.8x12.

* For the Ford Transit from MY 2019, this screw must also be used (Fig. 16, 18).

Make 2 notches on the inner side of the seal to include distance sleeves of the bracket, Fig. 15.

Replace the door seal, Fig. 18.

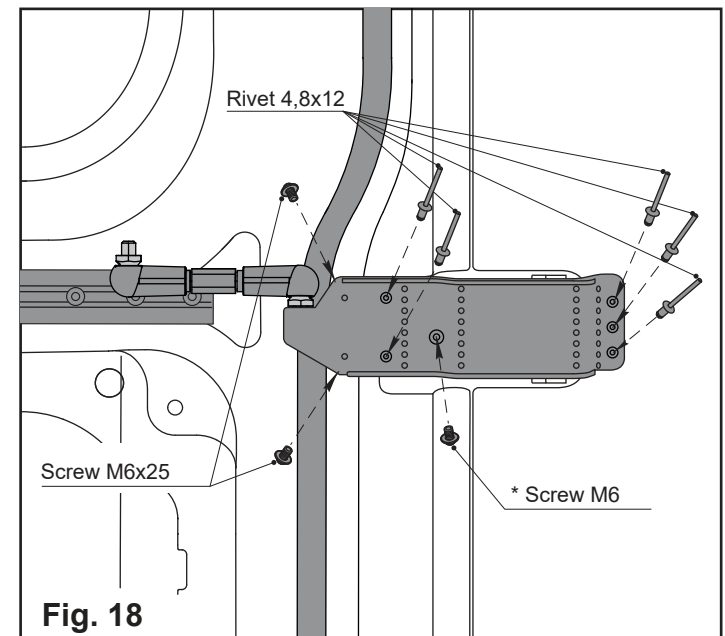
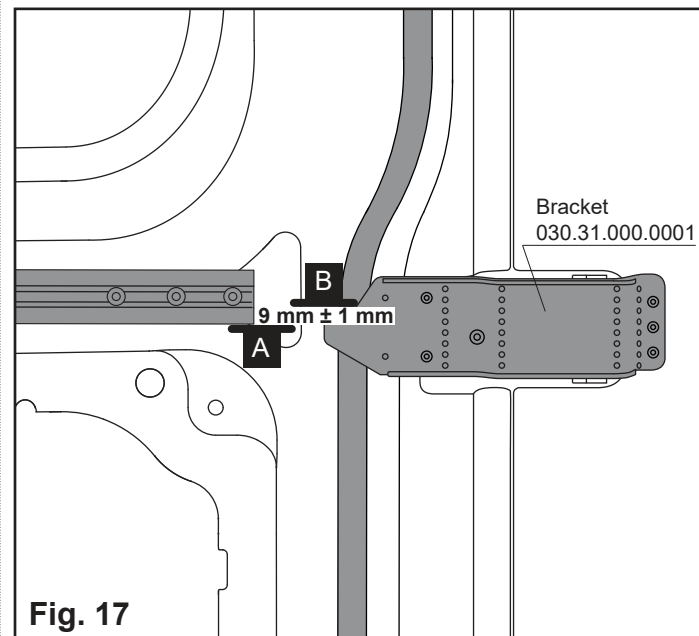
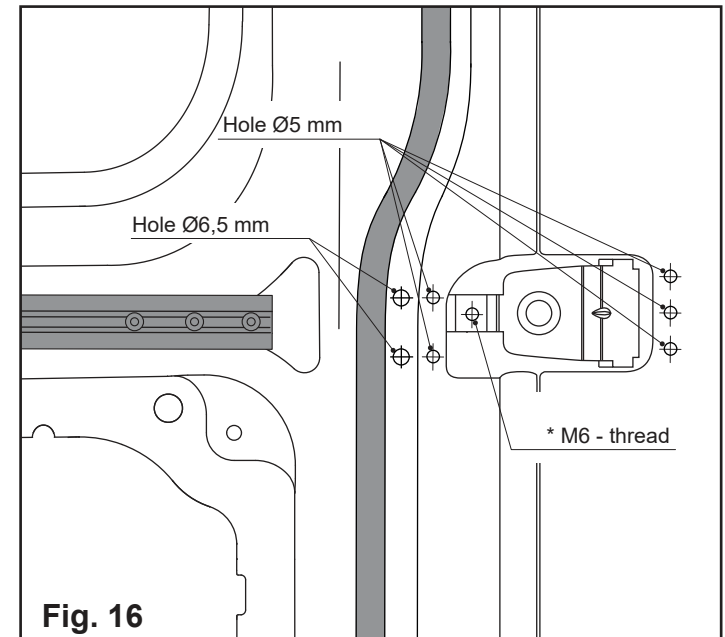
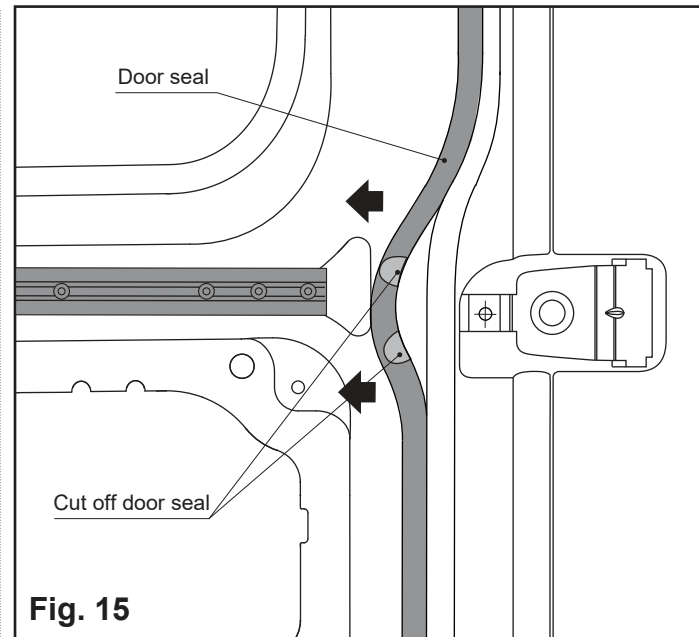

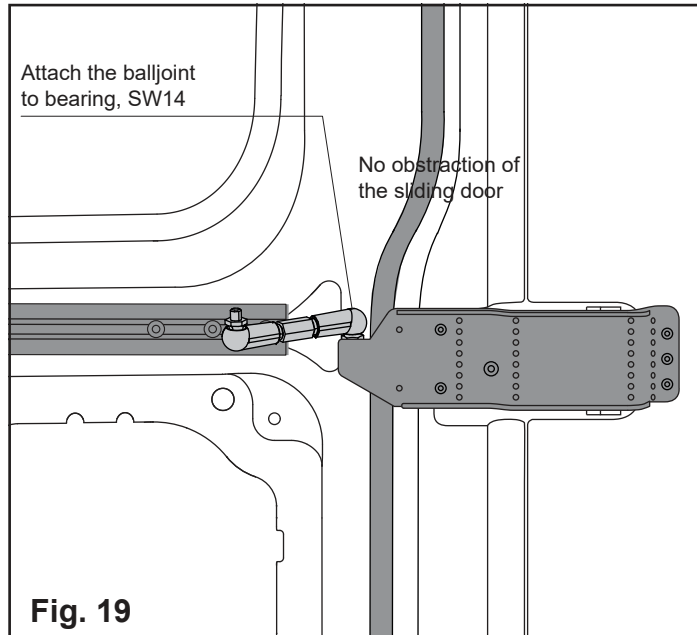

6.10 Preliminary preparation

Attach the balljoint with the bracket (SW14), Fig. 19.

Close the door manually.

Check to be sure that racks of the bearing item and the balljoint do not make the door closing difficult, Fig. 19.

Install the door drive on the rack, Fig. 20.

Connect the drive to the rear bearing with the balljoint (SW14).

For the desired end position in the open position
Install the stop angle. If necessary, two
two Ø3 mm holes can be drilled into the existing
holes, drilling depth approx. 5 mm, Fig. 21.

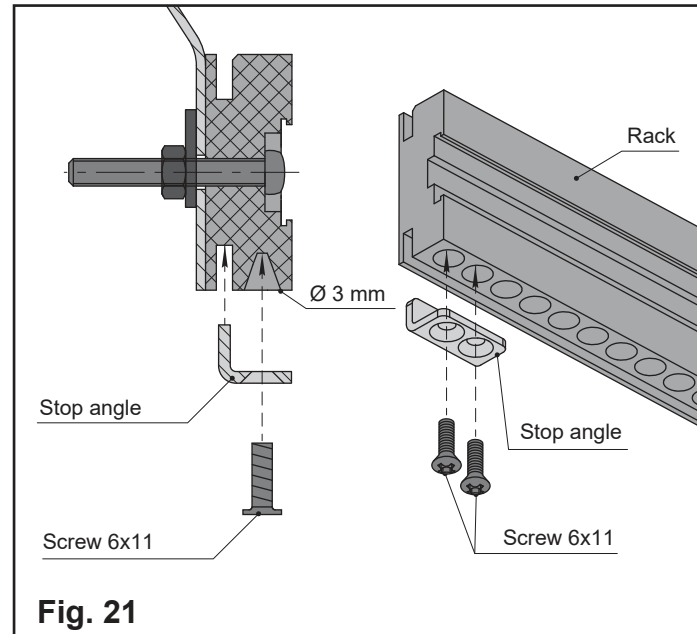
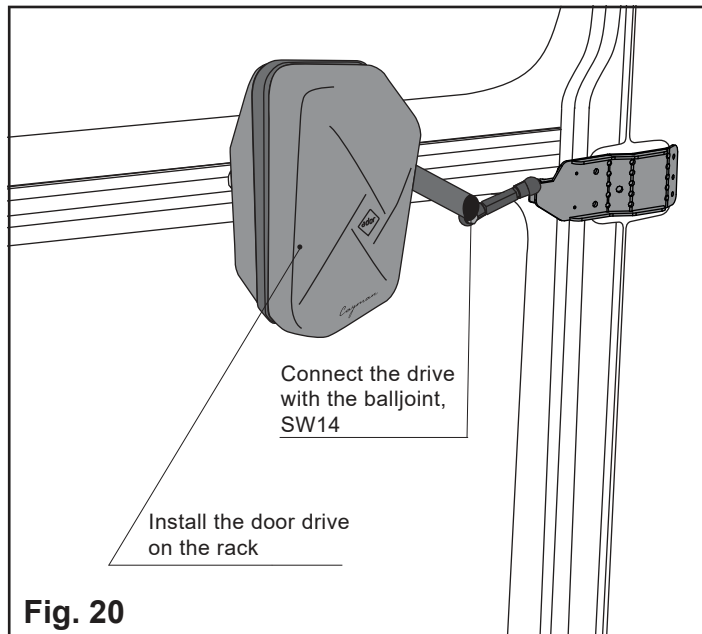

7 The first cycle

7.1 The first cycle of rack-and-pinion drive

Clean the rack housing from cuttings, Fig. 22, 2.

Connect the drive to the controller.

Insert the switch fuse 30A into the fuse block. Thereby, the controller will produce a long audio signal!

Press the control button. Thereby, the drive will close the door, and the controller will be producing audio signals for 1-2 sec.

After that, launch the opening operation. Thereby, the drive will open the door and slightly move till the block stop lock.

Then the drive will operate as usual.



Before detaching the drive (if needed) or disconnecting controller, unplug switch fuse 30A first.

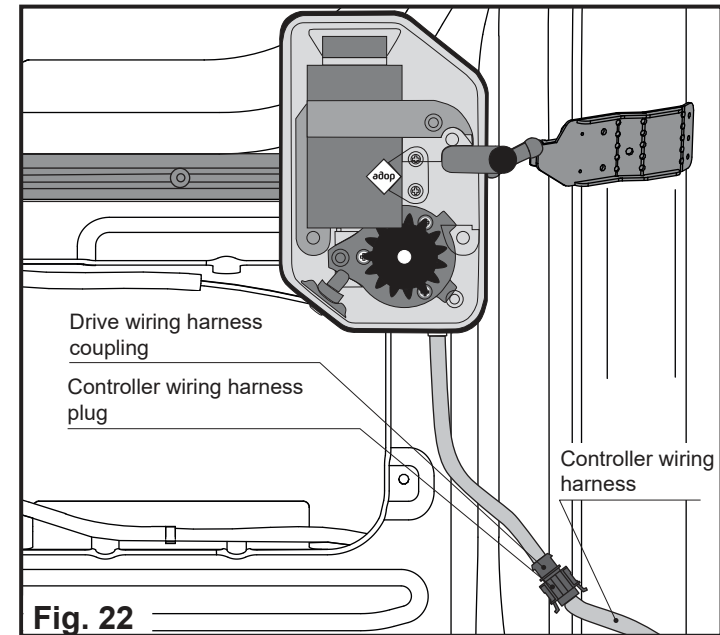

Fig. 22

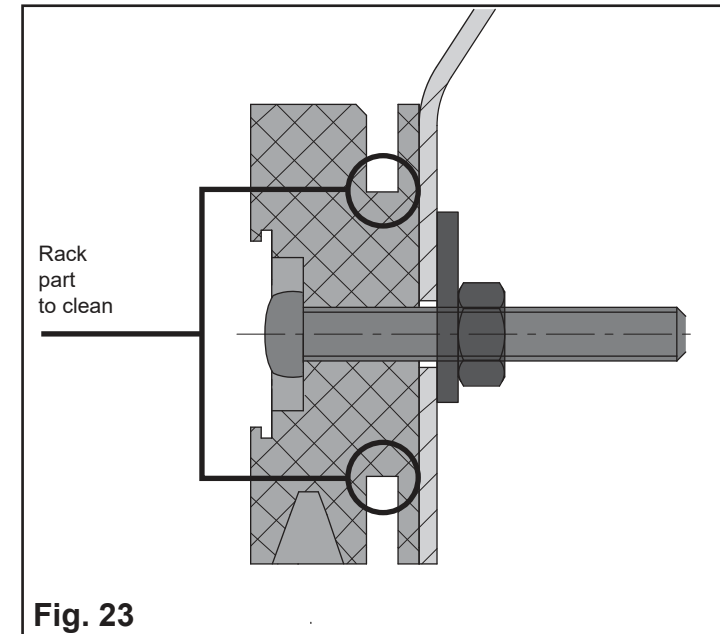

Fig. 23

7.2 Drive adjustment

Adjustment via the balljoint

Position of the balljoint with the sliding door correctly closed sliding door as shown in Fig. 24.

Adjust the length of the ball joint (Fig. 25) in such a way that the sliding door lies cleanly against the seal.

When correctly adjusted, the balljoint rests against the the rubber stop on the drive, Fig. 26.

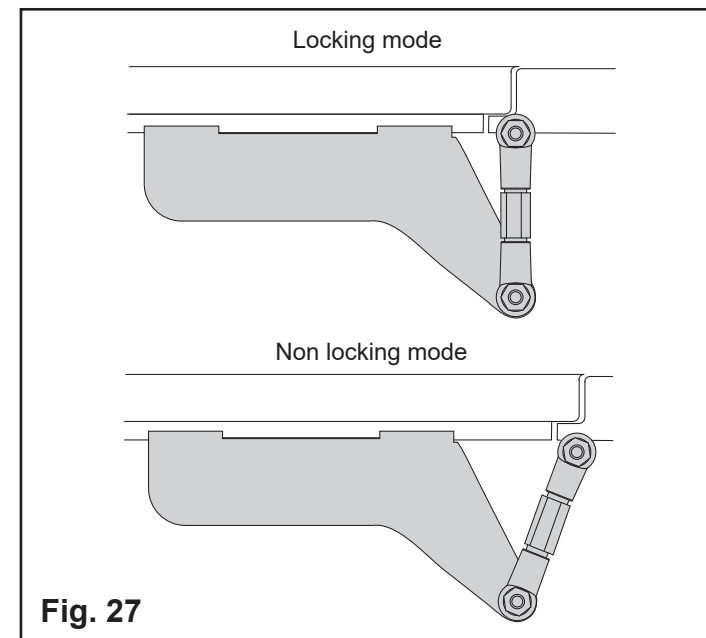
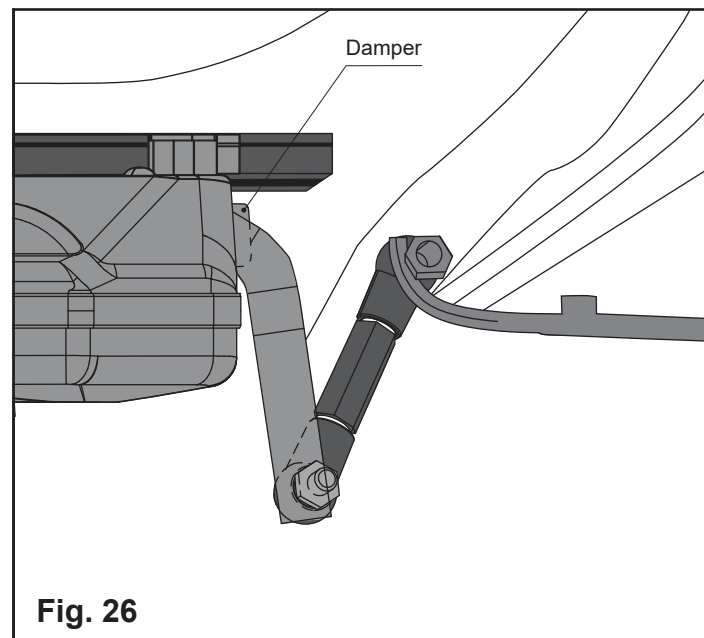
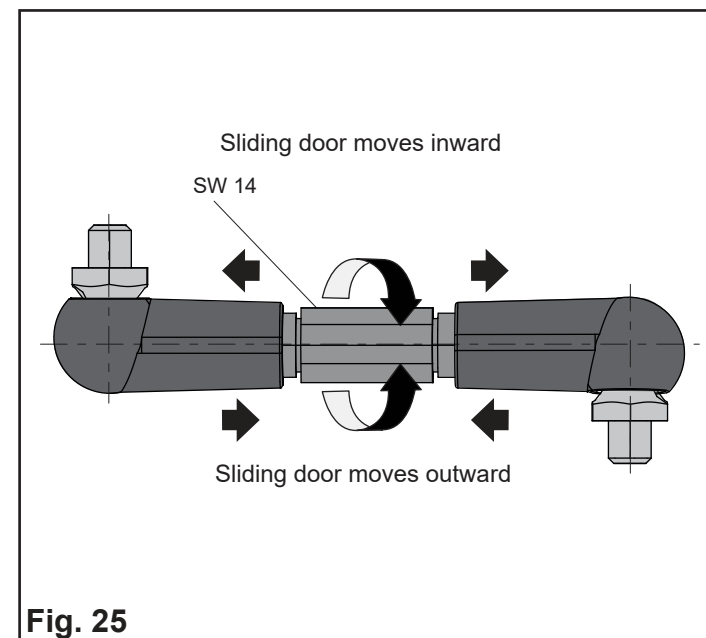
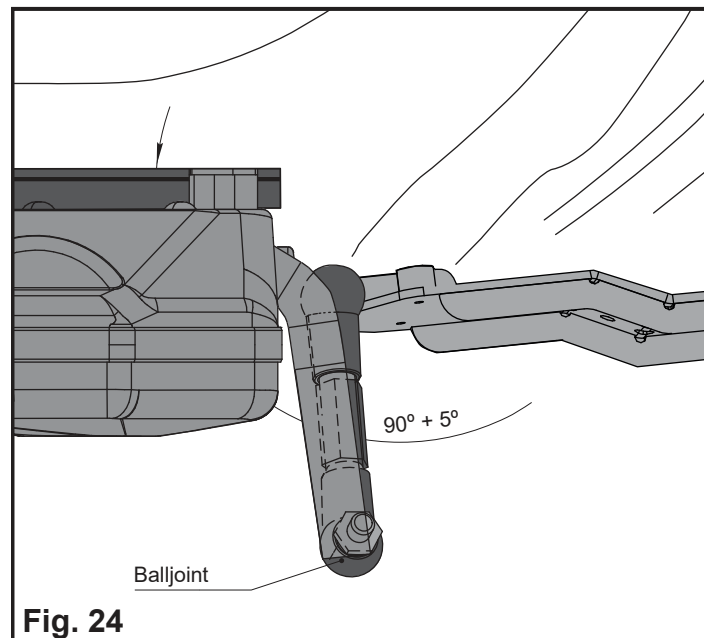

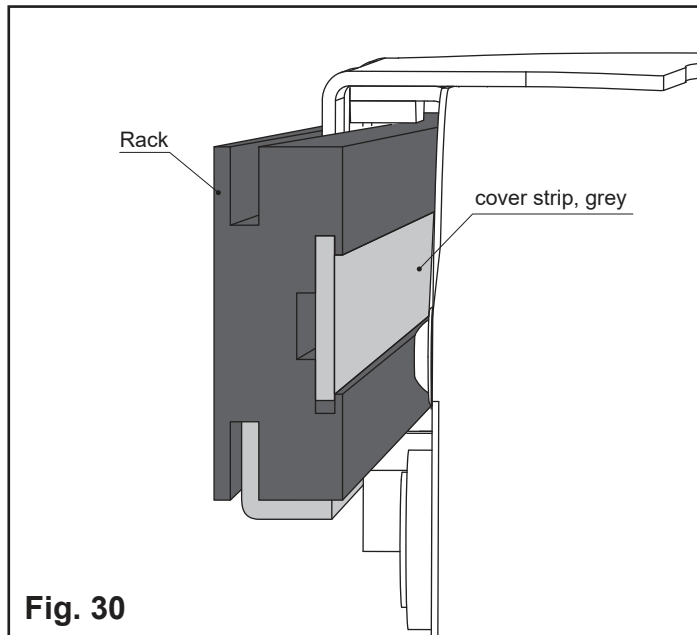
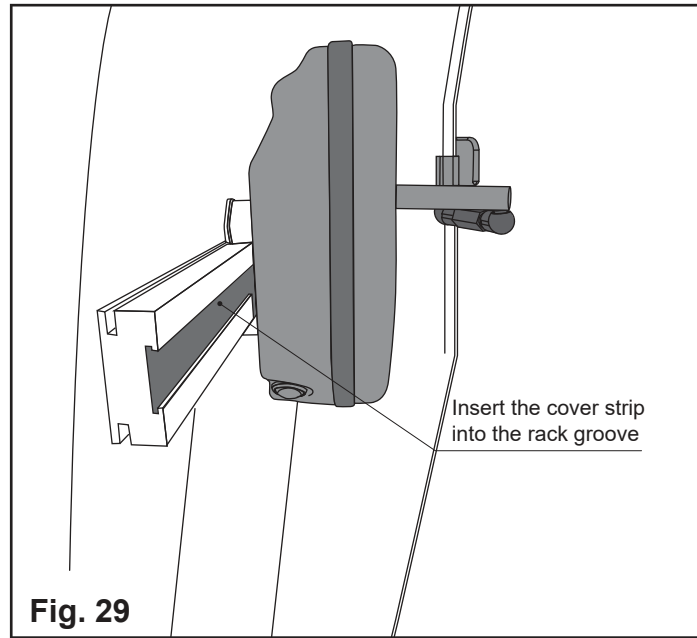
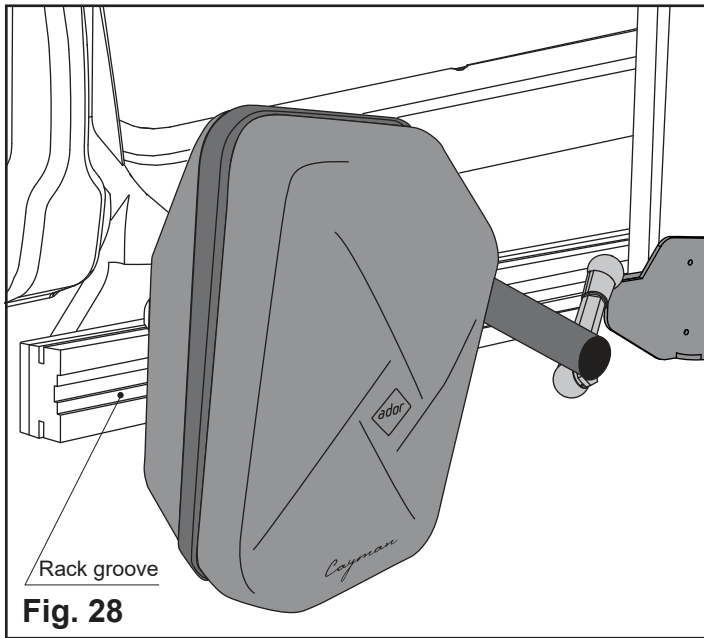

7.3 Monting of decorative cover strip

Cut the cover strip to fit the rack.

Carefully insert the cover strip into the rack groove as shown in Fig. 29 and 30.

7.4 Functions of the rack-and-pinion drive and setting the controller

OPENING / CLOSING THE SLIDING DOOR

Press the control button briefly, ~ 0.5 sec. The sliding door starts moving immediately after the control button is released.

STOPPING THE OPENING MOVEMENT

To stop the sliding door during the opening movement, briefly press the control button. Pressing the control button again closes the sliding door.

STOPPING THE CLOSING MOVEMENT

To stop the sliding door during the closing movement, press the control button once briefly. The sliding door immediately moves immediately to the open position.

AUTOMATIC RETURN DURING THE CLOSING MOVEMENT

If there is a risk of collision with or entrapment of persons or objects, the sliding door stops and returns to the open position.

SETTING THE DOOR OPENING WIDTH

Open the sliding door manually and move it to the desired open position. Now press and hold the control button until the acoustic signal sounds twice, ~ 10 sec, then release the control button. The new open position is saved.



The controller stops the drive 20 mm before this open position.
Recommendation: move the desired open position 20 mm further.

SETTING THE DOOR CLOSING SPEED

Press the control button until the acoustic signal sounds four times, ~ 20 sec, then release the button.

TO REDUCE THE SPEED, it is necessary to press the control button several times while the sliding door is opening. Each time the button is pressed, the speed is reduced by one level.

TO INCREASE SPEED, it is necessary to press the control button several times while the sliding door is closed. Each time the button is pressed, the speed is increased by one level.

RESTORING THE FACTORY SETTING

Press and hold the control button until the acoustic signal sounds five times, ~ 25 sec, then release the control button.



The drive settings are reset to the factory settings in the event of a power failure.

7.5 Warning sticker

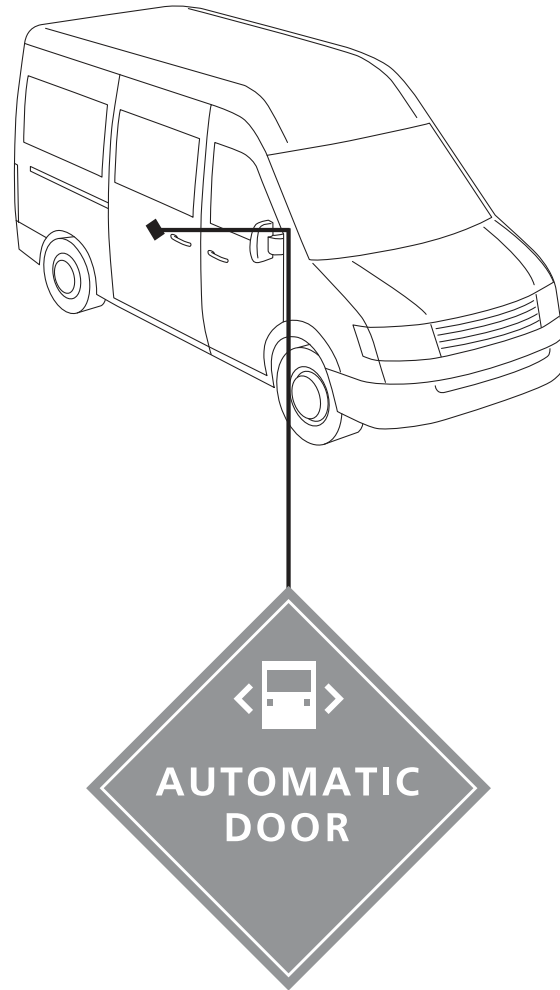

Self-adhesive warning sticker is located outside on the panel of the sliding door. It should be noticeable.

8 Optional accessories

8.1 Remote control

You can use the remote control to operate the sliding door at any time.

Attach the receiver sufficiently close to the controller.
Connect the two couplings of the wiring harness to the the plugs of the adapter.

Connect the coupling of the receiver to the plug of the adapter as shown.

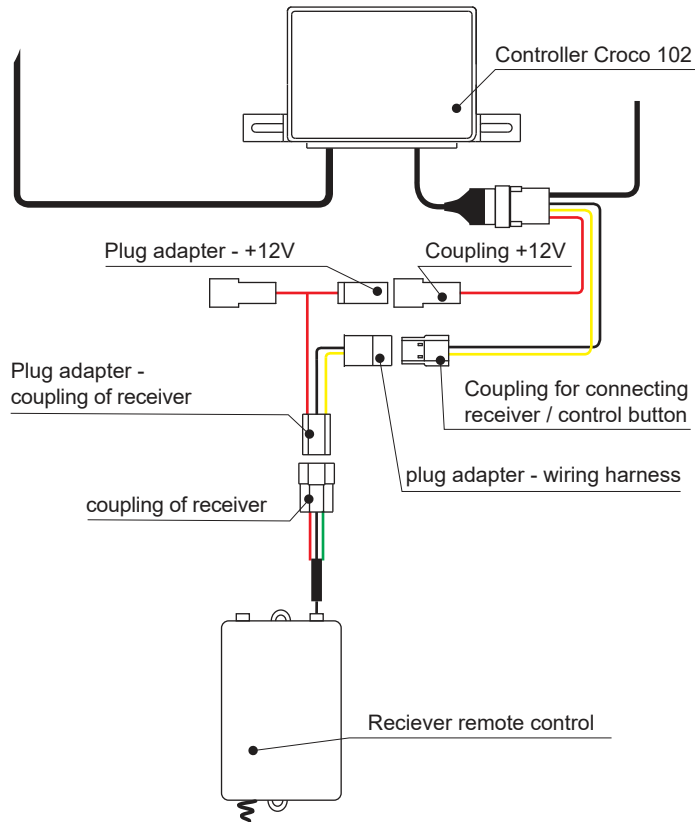

8.2 Touch button

This touch button reacts to a light touch.

In standby mode, it lights up GREEN.

When in operation, it lights up RED, no further contact possible.

Hole with Ø22.5 mm

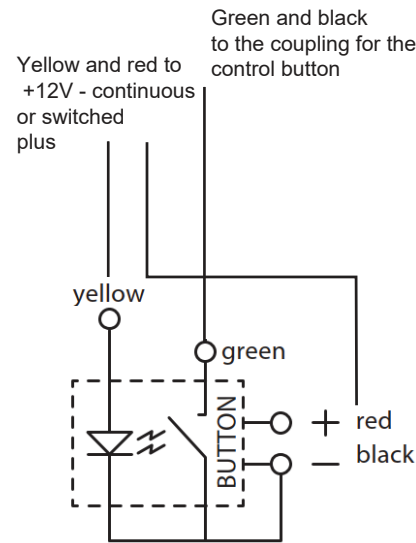

8.3 Uninterruptible power supply (UPS) (only Croco 107)

Regardless of the vehicle's supply voltage, the sliding door can be sliding door, e.g. for free opening.

Disconnect the plug connection from the main wiring harness and control unit.

Connect the main wiring harness plug to the coupling of the UPS and the coupling of the controller to the UPS plug, as shown.

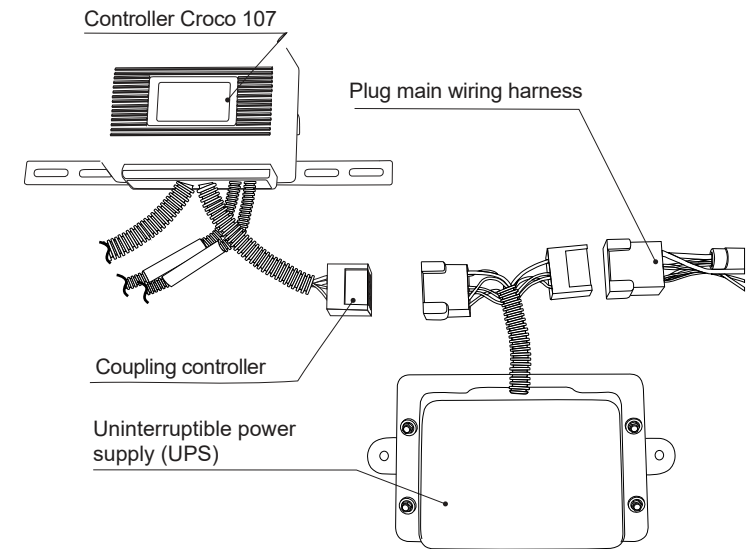

8.4 Handle cover outside 010.06.004.0003 and inside 010.06.004.0002

Put the outside handle cover to the handle itself, mark on and make two holes with diameter $\text{Ø}3,5$ mm. Screw up the cover on the handle with two self-tapping screws 4.2x16 from the hardware bag, as shown in fig. 31.

Put the inside handle cover to the marked place. Screw up the cover with the self-tapping screw 4.2 x 16 from the hardware bag, as shown in fig. 32.

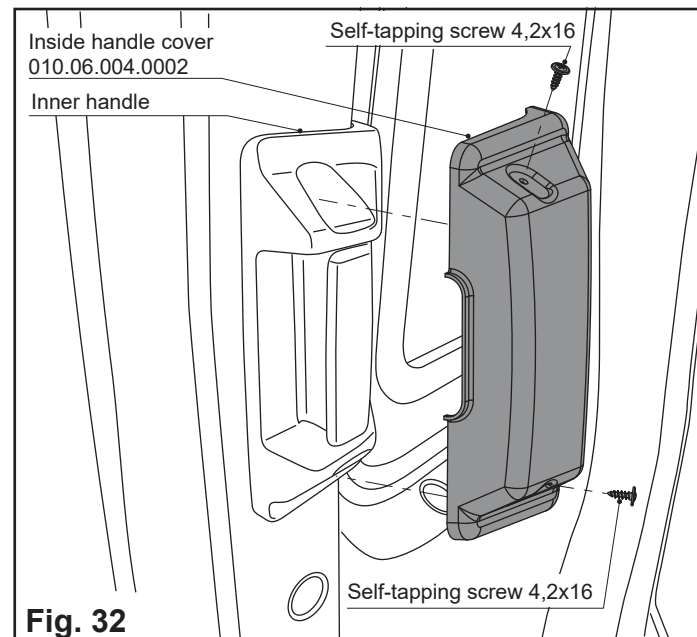
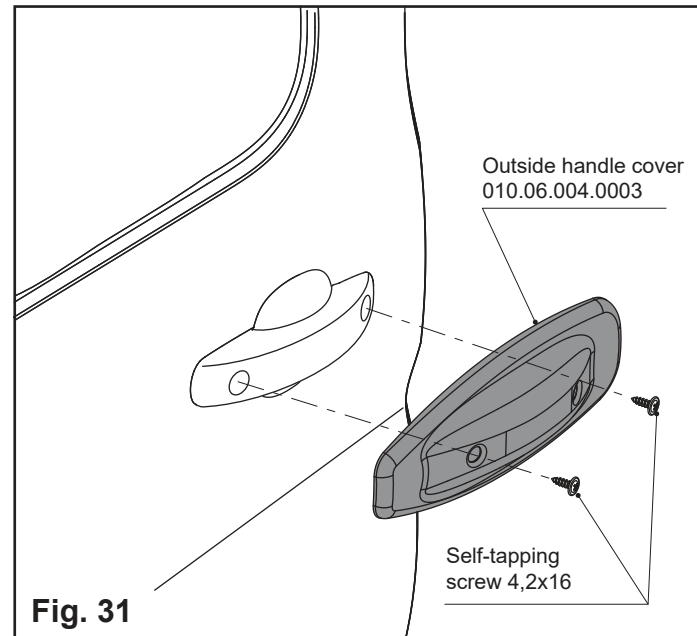

8.5 Safety edge 030.18.000.0020 on door edge

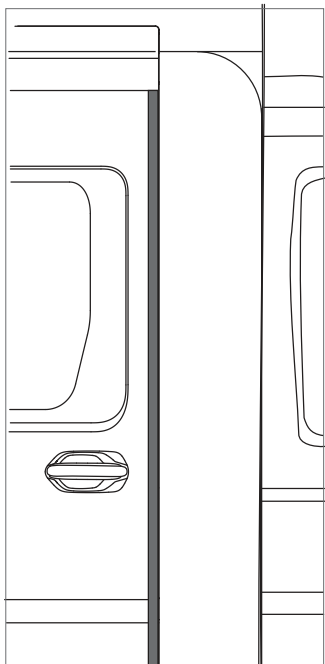

Fig. 32

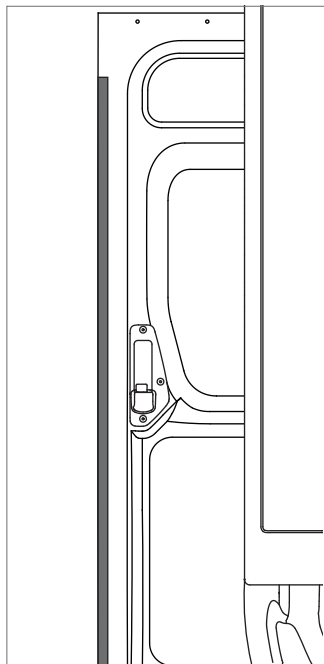

Fig. 33

To fit the safety edge, degrease both sides of the outer closing edge of the sliding door using a grease-soluble cleaner.

Stick the double-sided adhesive tape over the entire length of the outer and inner edge (Fig. 32, 33).

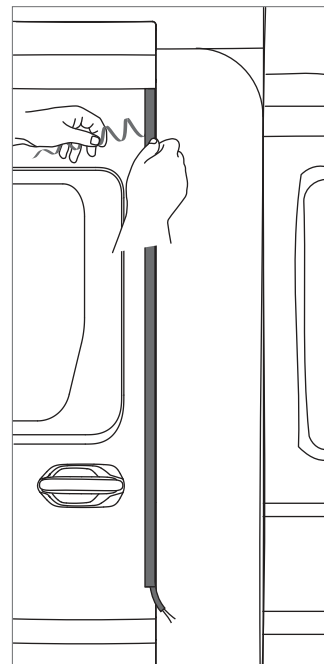

Fig. 34

Apply primer (adhesion promoter) to the inside of the safety edge.

Slide the safety edge over the closing edge without removing the protective film.

Then carefully remove the protective film from the double-sided adhesive tape on the outside (Fig. 34) and press the safety edge firmly into place.

Carry out the same procedure on the inside (Fig. 35).

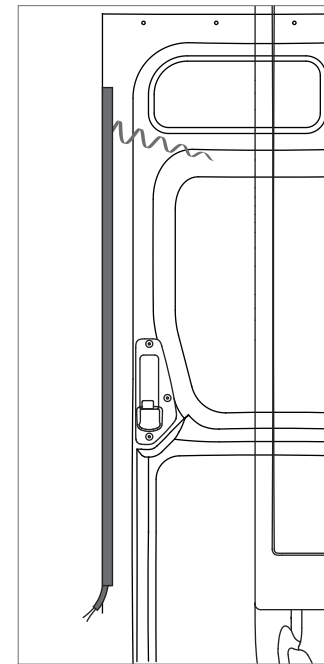

Fig. 35

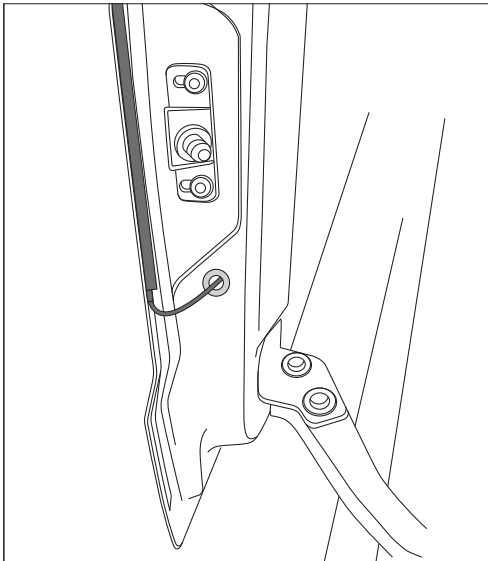

Fig. 36

Drill a hole (hole at least Ø8 mm for the rubber grommet) in the front face of the sliding door, to feed through the cables of the safety edge and insert a rubber grommet (Fig. 36).

Connect the cables of the safety edge with the cables of the coupling, e.g. Wago terminal.

Plug the coupling into the plug of the remote control (Fig. 37).

Attach the remote control to a suitable location using double-sided adhesive tape (Fig. 38).

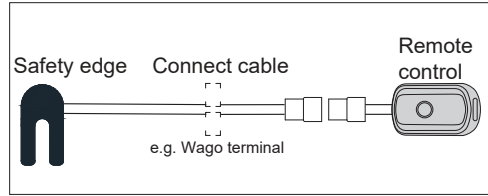

Fig. 37

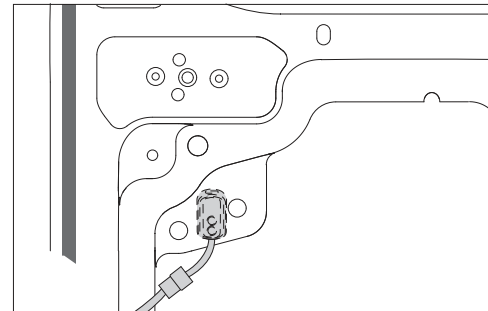
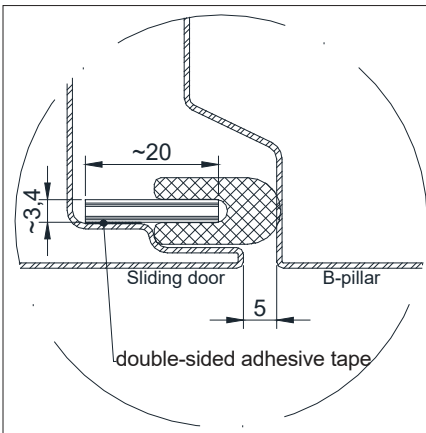

Fig. 38



Option for other vehicles:

You need a flexible rectangular profile approx. 3.4x20mm, e.g. rubber, in the length of the safety edge. After priming, stick the double-sided adhesive tape to the rectangular profile. Then carefully remove the protective film from the double-sided adhesive tape and stick the corner profile to the inside of the sliding door.



The safety edge must not be deformed or pressed by the B-pillar.

Proceed as described on page 26, Fig. 32 and following.

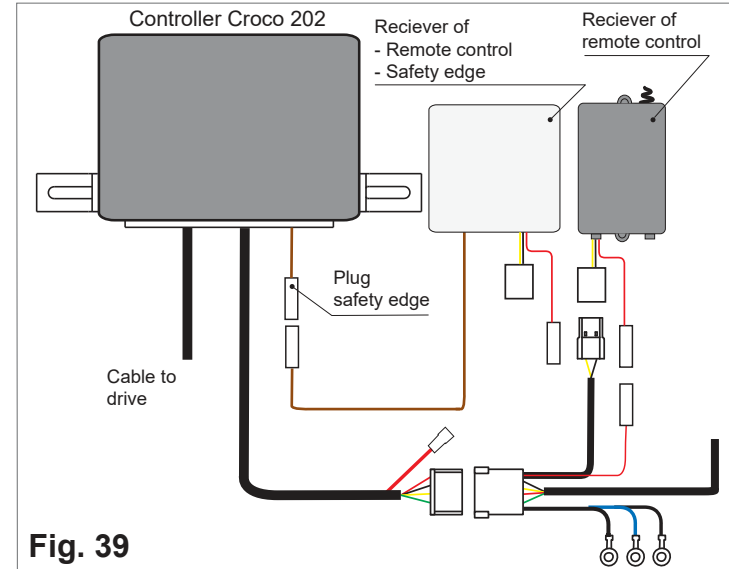

Fig. 39

Croco 202: Connect the corresponding receiver to the control unit as shown in Fig. 39.

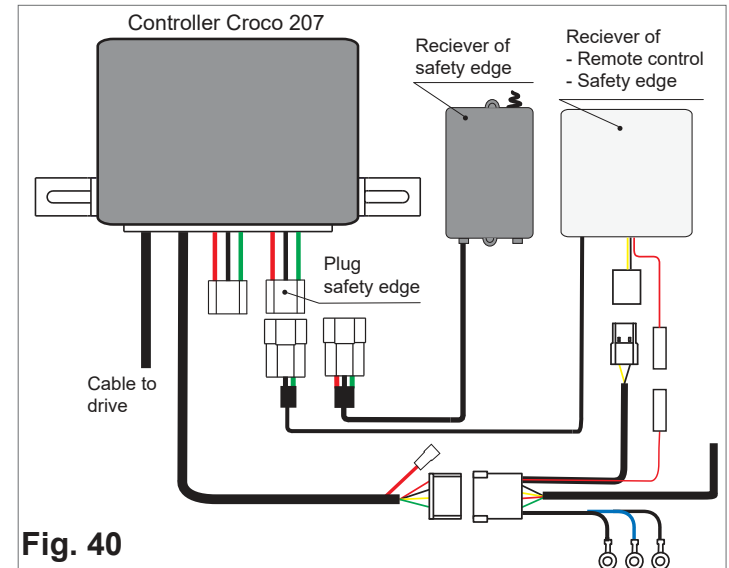

Fig. 40

Croco 207: Connect the corresponding receiver to the control unit as shown in Fig. 40.

9 Notes

9.1 Emergency door opening from the outside

1. Remove the cover, if present, (Fig. 41).
2. Pull and hold the door handle (Fig. 42).
3. Pull the left-hand part of the door towards you (Fig. 42).
4. Open the door with the door handle to the left, (Fig. 42).

9.2 Emergency door opening from the inside

1. Turn and hold the door handle (Fig. 43).
2. Push the drive diagonally outwards to the left (Fig. 43).
3. Open the door with the door handle to the right, (Fig. 43).

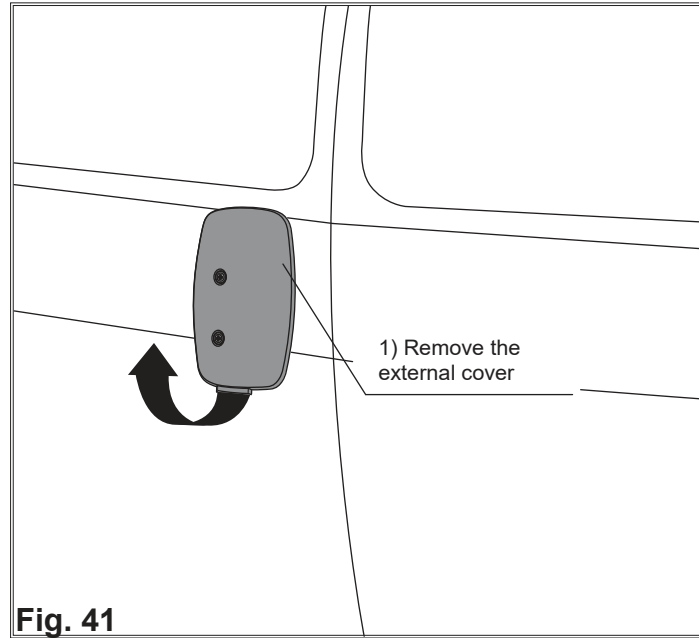

Fig. 41

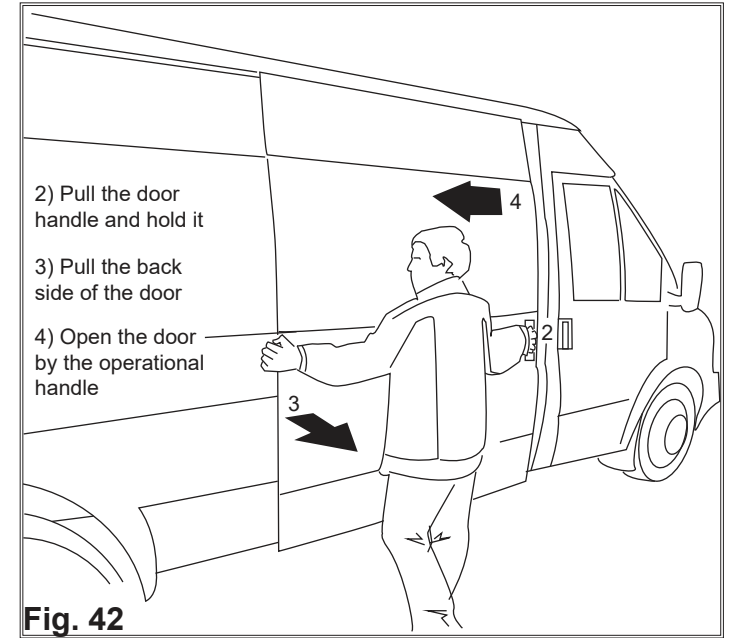

Fig. 42

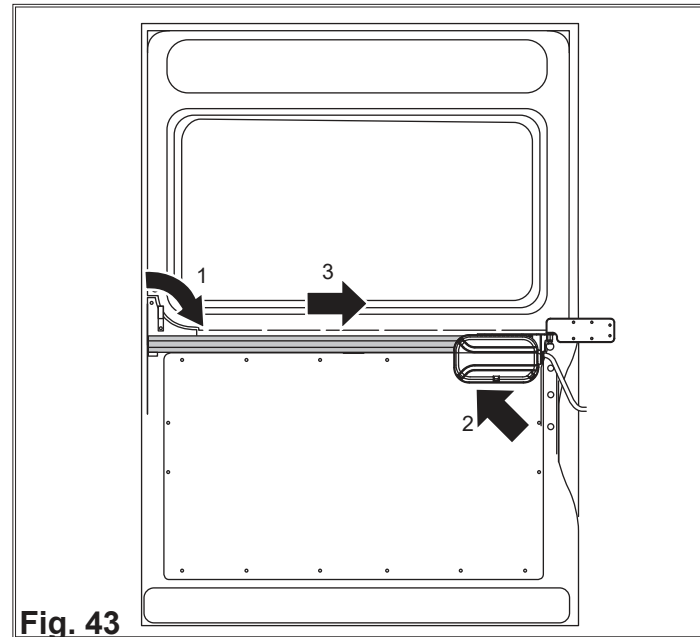
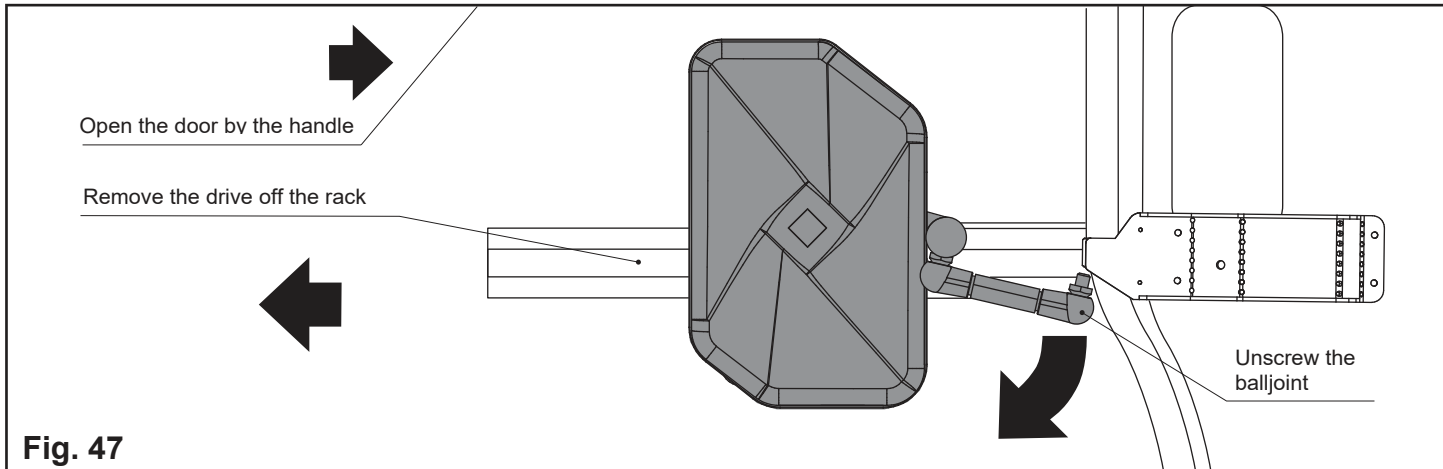
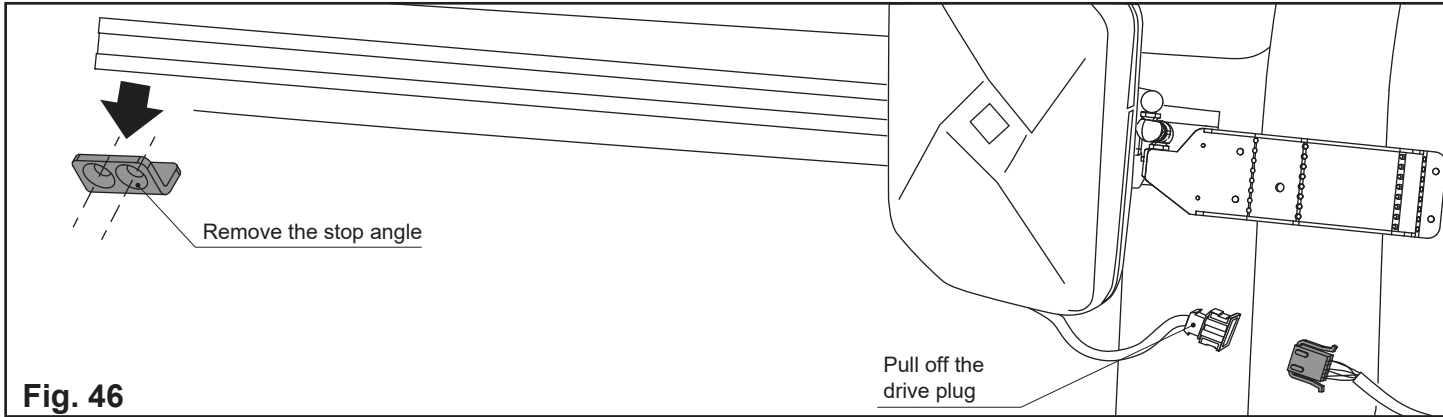
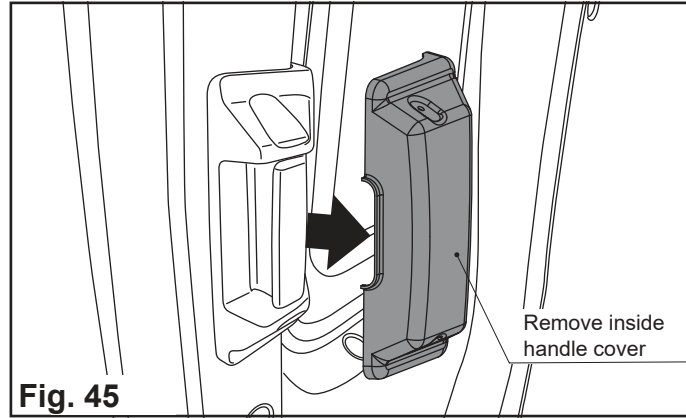
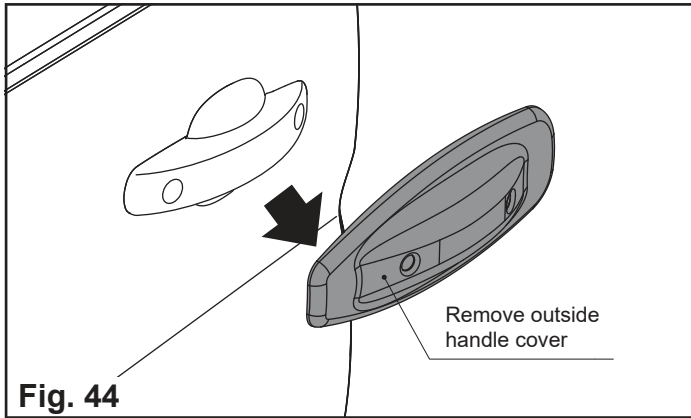

Fig. 43



10 Manual mode reset

10.1 Rack-and-pinion drive

1. Remove the cover, if present (Fig. 44).
2. Remove the stop angle (Fig. 44).
3. Pull off the drive plug (Fig. 44).
4. Unscrew the balljoint (Fig. 45).
5. Remove the drive off the rack (Fig. 45).

The sliding door now operates manually.

11 Extensions

11.1 Switching the remote control receiver on/off with the vehicle's central locking system (30.99.000.0001)

- > Operation via handle on the outside and inside
- > Signal scanning of the vehicle's central locking system

The 'Remote control with 1 key' accessory is required

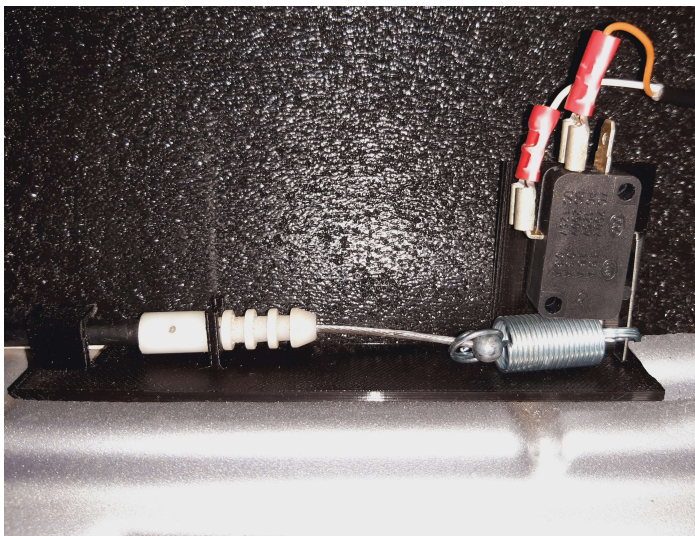

Assembly:

1. Lay the Bowden cable inwards
2. Glue/screw the bracket with switch to the surface, see photo
3. Hook the Bowden cable into the spring loop and compress the spring loop with pliers, if necessary adjust the pre-tension using the notches in the Bowden cable
4. Connect the two cables of the remote control to the two cables of the switch as required, secure the remote control with the double-sided adhesive tape or stow it away elsewhere

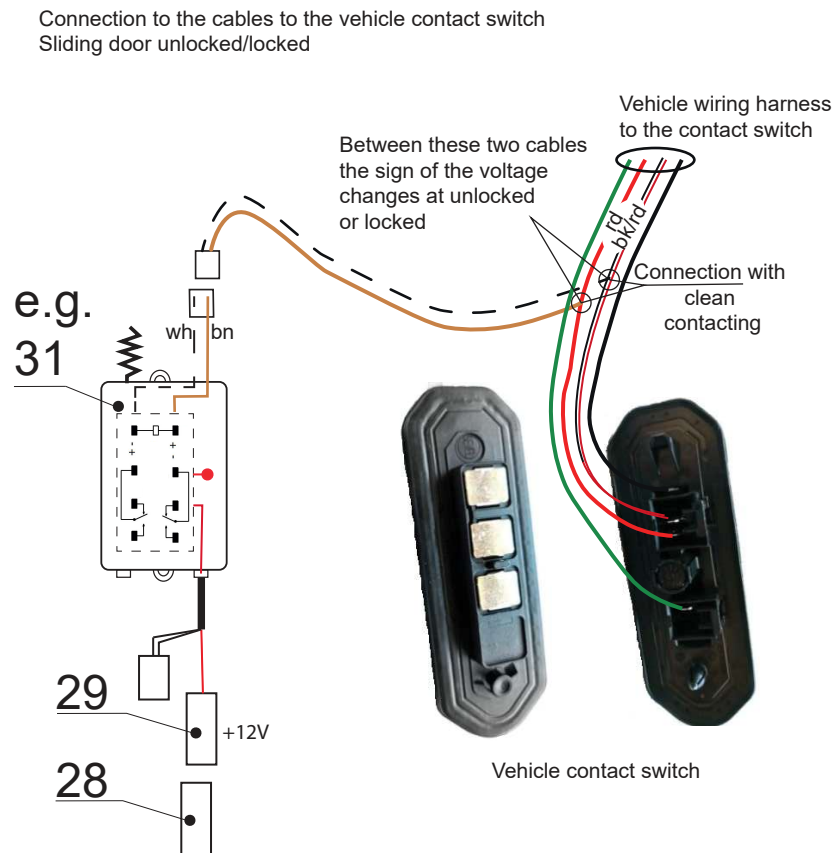

Illustration: Extract from 6.2 Wiring harness and connection diagram

The scope of delivery is customised to your requirements.

We recommend that you purchase a key for the remote control (item no. 30.00.000.0038) if you select the following accessories:

- > Safety edge

11.2 Coupling the electric step with the Ador drive (30.99.000.0011 und 30.99.000.0013)

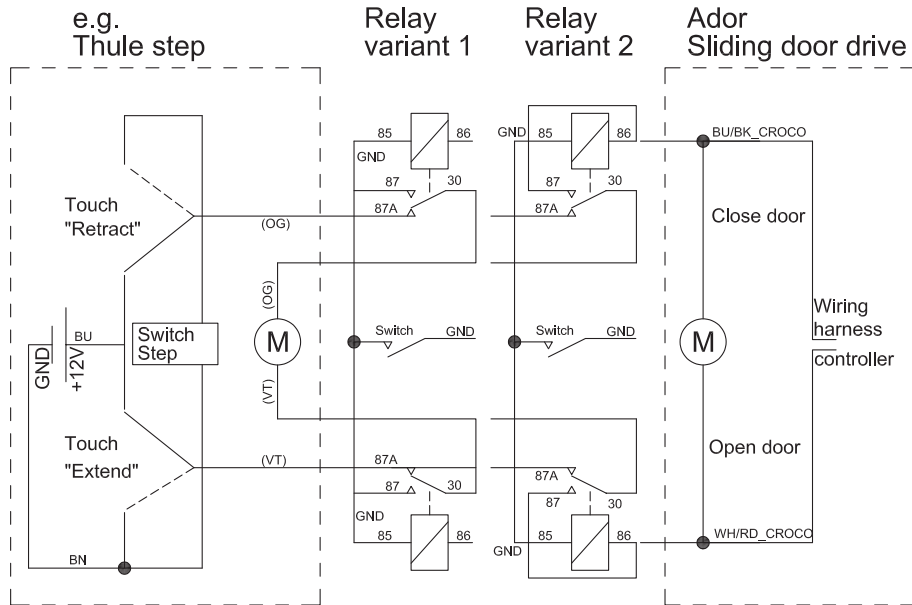

The relays are used to switch the step depending on the movement of the sliding door.

These relays can be switched with a switch so that the step does not move every time the sliding door moves.

The scope of delivery is customised to your requirements.

We recommend that you send us your wiring diagram for the step.

The circuit diagram shows 2 variants of the relay connections to the step switch

(colour) may vary



Relay connection plug colour codes:
30 - RD, 85 - BK, 86 - WH, 87 - BU, 87A - YE

11.3 Connection diagram of the extensions

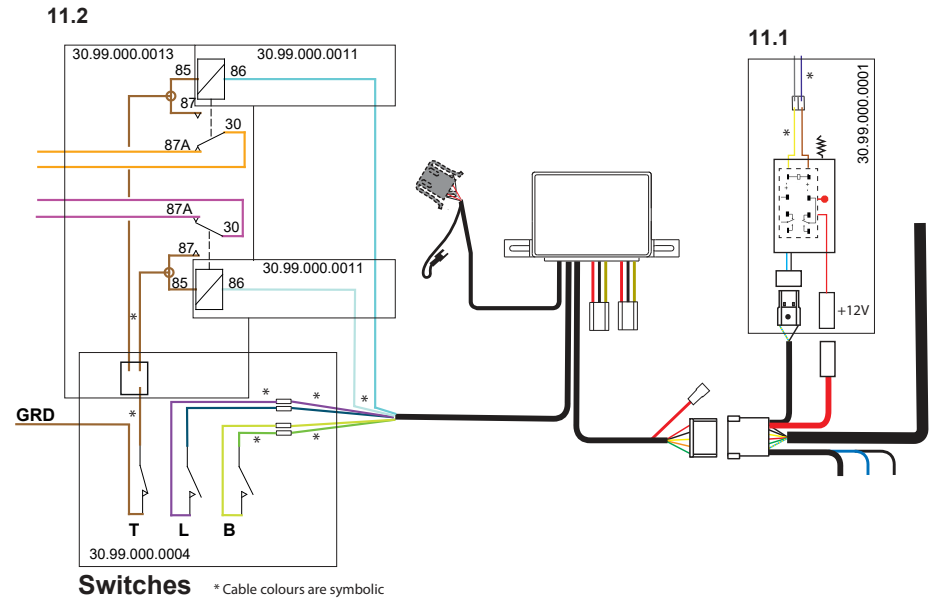

Switches * Cable colours are symbolic

11.1 Remote control variant

Door handle actuation has a remote control

Safety edge has a remote control

Remote control battery: 2x CR2016

Door handle actuation and safety edge have a common remote control

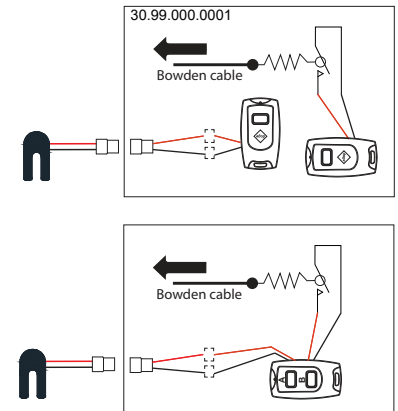

12 Information

For warranty claims and service enquiries, please contact our representative in Germany.

Ador Germany
c/o BBT Sauer Engineering Office

Fellhornweg 24
D-89231 Neu-Ulm

+49 731 250 68 210
info@ador-eu.de
<https://ador-eu.de/>

The reprinting or other reproduction of documentation and accompanying documents of the products, even in part, is only in extracts, is only permitted with the express authorisation of the responsible ADOR country representative.

Subject to technical changes.